



Sixth framework programme of  
the European Commission

GOCE-CT-2003-505401

## RIVERTWIN

### A regional model for integrated water management in twinned river basins

**Instrument:** Specific Targeted Research Project (STREP)

**Priority:** Sustainable development, Global Change and Ecosystems

***Deliverable reference number and title:***

D5 Tested Submodel for surface water quality in the Neckar basin

Due date of deliverable: Feb. 05

Actual submission date: Feb. 05

Start date of project: 01.03.2004

Duration: 3 years

***Organisation name of the lead contractor for this deliverable***

Aristotle University of Thessaloniki (AUTH)

**Revision: Final**

Project co-funded by the European Commission within the Sixth Framework programme (2202-2006)		
Dissemination level		
PU	Public	X
PP	Restricted to other programme participants (including Commission Services)	
RE	Restricted to group specified by the consortium (including Commission Services)	
CO	Confidential, only for members of the consortium (including Commission Services)	



Tested Submodels for surface water quality in the Neckar basin

MONERIS and QUAL2K Models  
REFERENCE MANUALS AND TESTING

February 2005



Prepared by the Lead Contractor  
*Aristotle University Thessaloniki (AUn), Hydraulics Laboratory*

## TABLE OF CONTENTS

The MONERIS Model	p. 4
The QUAL2K Model	p. 20

## THE MONERIS MODEL

The model **MONERIS** (**MO**delling **N**utrient **E**missions in **R**iver **S**ystems) was developed and applied to estimate the nutrient inputs into river basins of Germany by point sources and various diffuse pathways. The model is based on data of river flow and water quality as well as a geographical information system (GIS), which includes digital maps and extensive statistical information. Whereas point emissions from waste water treatment plants and industrial sources are directly discharged into the rivers, diffuse emissions into surface waters are caused by the sum of different pathways, which are realised by separate flow components (see Figure 1). This separation of the components of diffuse sources is necessary, because nutrient concentrations and relevant processes for the pathways are mostly very different.

Consequently seven pathways are considered:

- point sources
- atmospheric deposition
- erosion
- surface runoff
- groundwater
- tile drainage
- paved urban areas

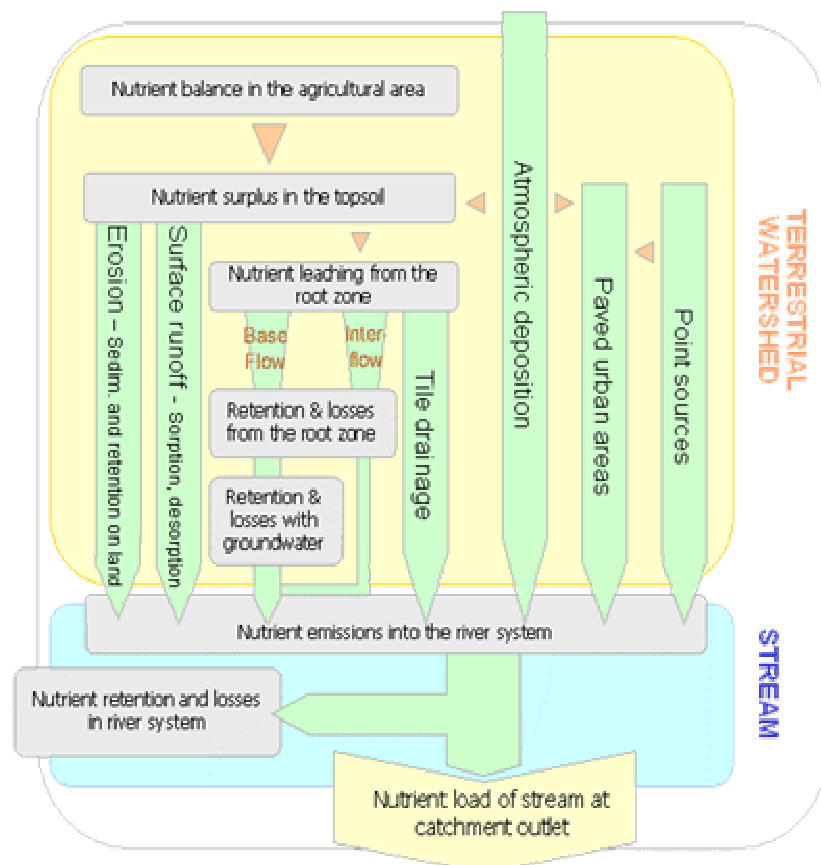

Figure 1: Point and diffuse pollutant pathways in the MONERIS model (Behrendt et al. 2000).

With the exception of inputs through atmospheric deposition and direct industrial discharges, for which results of other studies were directly used, MONERIS carries out a balance for each input pathway, i.e. nutrient influx in the catchment and output, i.e. nutrient inputs in surface waters. Through this it is possible to calculate specific retentions and losses on the way from the source to input to appearance in the water body and also possible future inputs with changed conditions in the form of scenarios. The nutrient loads leaving the catchment were calculated from the determined sum of inputs from all individual pathways including internal retention and losses of the water body.

## **A. Inputs via point sources**

### **A<sub>1</sub>. Nutrient inputs via municipal wastewater treatment plants**

The basis for the estimation of the phosphorus and nitrogen inputs from municipal wastewater treatment plants (WWTP) is the determination of the necessary entry parameters. For this, a database is generated for every recorded WWTP on which further calculations are based. It comprises the following information:

- Rate of utilisation (AU)
- Treated population equivalents (EW<sub>AU</sub>)
- Treated population equivalents (inhabitants) (E<sub>KA</sub>)
- Treated population equivalents (indirect industrial discharges) (EGW)
- Yearly quantity of water treated partitioned into:
  - (1) Domestic wastewater (Q<sub>H</sub>)
  - (2) Industrial and commercial wastewater (Q<sub>GEW</sub>)
  - (3) External water (Q<sub>F</sub>)
  - (4) Urban wastewater (Q<sub>T</sub>)
  - (5) Storm wastewater (Q<sub>N</sub>)
  - (6) Total wastewater (Q<sub>GES</sub>)

### **A<sub>2</sub>. Nutrient inputs via direct industrial dischargers**

If data has already been published for individual catchment areas, this will be used directly. Where only summary data available for extensive areas, the division of inputs in the individual catchment areas will be based on the urban areas after CORINE-Landcover.

## **B. Inputs via diffuse sources**

The considered pathways for diffuse nutrient inputs are:

- atmospheric deposition
- erosion
- surface runoff
- groundwater
- tile drainage
- paved urban areas

The methods and database for estimation of at least some paths are clearly different. The formulation of the methods, at first, succeeds especially for the two nutrients nitrogen and phosphorus. Since the behaviour of phosphorus and nitrogen in the environment is very different, the methods for the two elements are not always the same. The starting point for the modelling of nutrient inputs into every river basin is an estimate of the water balance:

$$Q = Q_{GW} + Q_{DR} + Q_{RO} + Q_{URB} + Q_{AD}$$

where Q = average measured runoff [m<sup>3</sup>/s],

Q<sub>GW</sub> = base flow and natural interflow [m<sup>3</sup>/s],

Q<sub>DR</sub> = tile drainage flow [m<sup>3</sup>/s],

$Q_{RO}$  = surface runoff from non-paved areas [ $m^3/s$ ],  
 $Q_{URB}$  = surface runoff from urban areas [ $m^3/s$ ] and  
 $Q_{AD}$  = result of the balance between direct precipitation on the freshwater surfaces and the evaporation from these surfaces [ $m^3/s$ ].

The individual components of this water-balance are calculated from the precipitation by means of empirical equations as average values for a particular period of five years with the exception of the base flow. This is essential because the calculation approach should exclude errors caused by periods shorter than 5 years in hydrological and meteorological time series.

### **B<sub>1</sub>. Nutrient surpluses on the agricultural area and their long term change**

Most diffuse nutrient input is caused through agriculture. Therefore, the model for the quantification of nutrient inputs in the river systems must consider these agricultural activities in an appropriate way. One of the main factors, which determines the size of the nutrient loadings from diffuse sources, is the yearly surplus of nutrients on agricultural areas. The nutrients from the agricultural activity through the erosion, the surface runoff, the tile drainage and the groundwater pathways, go into the river system.

#### **B<sub>1.1</sub>. Erosion**

On the basis of the fitted soil erosion maps, average soil loss values were determined for every basin. For the whole of Germany, a mean of 3.8 t/(ha· a) is estimated for the annual soil loss from arable land. In a further step, a new erosion map is developed in which the fitted soil losses were used only for the German states without published reference soil loss data. This map forms the basis for all further calculations. For areas with natural erosion (mountainous and rocky areas), a constant value of 2.0 t/(ha· a) is used. The nutrient input by erosion can be calculated for each basin using Equations 3.34 and 3.35:

$$EER_P = P_{BODEN} \cdot ER_P \cdot SED \quad (3.34)$$

$$EER_N = N_{BODEN} \cdot ER_N \cdot SED \quad (3.34)$$

where  $EER_{N,P}$  = nutrient input via erosion [t/a].

$ER_N$  = enrichment ratio for nitrogen.

$ER_P$  = enrichment ratio for phosphorus

$N_{BODEN}$  = nitrogen content in the topsoil

$P_{BODEN}$  = phosphorus content in the top-soil

$SED$  = sediment input

#### **B<sub>1.2</sub>. Surface runoff**

The calculation of surface runoff is based on the simplified approach according to LIEBSCHER & KELLER (1979). With this, the surface runoff and the average total yearly runoff can be calculated using the average annual precipitation, the average summer half-year precipitation and the average winter half-year precipitation.

$$q_G = 0,86 \cdot N_J - 111,6 \cdot \frac{N_{SO}}{N_{WI}} - 241,4$$

with  $q_G$  = average yearly specific runoff [ $mm/(m^2 \cdot a)$ ],

$N_J$  = average annual precipitation [ $mm/(m^2 \cdot a)$ ],

$N_{SO}$  = average precipitation in the summer half year [ $mm/(m^2 \cdot a)$ ] and

$N_{WI}$  = average precipitation in the winter half year [ $mm/(m^2 \cdot a)$ ].

The surface runoff is calculated using the following power function (see Equation 3.9), from the US SOIL CONSERVATION SERVICE (1972) and also proposed by *German Association for Water*

*Resources and Land Improvement (Deutscher Verband für Wasserwirtschaft und Kulturbau)* (DVWK, 1984):

$$q_{RO} = q_G \cdot 2 \cdot 10^{-6} \cdot (N_J - 500)^{1,65}$$

where  $q_{RO}$  = specific surface runoff [mm/(m<sup>2</sup>· a)].

For the estimation of the total surface runoff from the unpaved areas in a basin, it is assumed that these runoff components do not occur in forested and wetland areas or in freshwater bodies itself and mined lands (e.g. open cast pits). Then one can calculate the average total surface runoff from unpaved areas for every basin with the following equation:

$$Q_{RO} = q_{RO} \cdot (A_{LN} + A_{OF}) \cdot 1000$$

where  $Q_{RO}$  = surface runoff from non-paved areas [m<sup>3</sup>/a],  
 $A_{LN}$  = agricultural area [km<sup>2</sup>] and  
 $A_{OF}$  = open area (mountainous areas and areas with natural vegetation) [km<sup>2</sup>].

For the further calculations, it is assumed that all of the surface runoff reaches the river system. The estimation of nutrient inputs via surface runoff considers only the dissolved nutrient components transported with the surface runoff into river systems. The nutrient concentration in surface runoff of every basin can be estimated as area-weighted mean of the concentrations in the surface runoff of the different land use categories. For that it is necessary to divide the agricultural areas into arable land and grassland. For the area-weighted concentrations of nitrogen and phosphorus in surface runoff, the following is valid:

$$C_{RO_{N,P}} = \frac{C_{RO_{ACKER_{N,P}}} \cdot A_{ACKER} + C_{RO_{GRÜN_{N,P}}} \cdot A_{GRÜN} + C_{RO_{OF_{N,P}}} \cdot A_{OF}}{A_{ACKER} + A_{GRÜN} + A_{OF}}$$

where  $C_{RO_{N,P}}$  = nutrient concentration in surface runoff [mg/l],  
 $A_{ACKER}$  = area of arable land [km<sup>2</sup>],  
 $A_{GRÜN}$  = grassland area [km<sup>2</sup>],  
 $A_{OF}$  = open area [km<sup>2</sup>],  
 $C_{RO_{ACKER_{N,P}}}$  = nutrient concentration in surface runoff from arable land [mg/l],  
 $C_{RO_{GRÜN_{N,P}}}$  = nutrient concentration in surface runoff from grassland [mg/l]  
and  
 $C_{RO_{OF_{N,P}}}$  = nutrient concentration in surface runoff from open land [mg/l].

The nutrient input via surface runoff to the river system is therefore:

$$ERO_{N,P} = \frac{C_{RO_{N,P}} \cdot Q_{RO}}{1000}$$

where  $ERO_{N,P}$  = nutrient input via surface runoff [t/a].

### B<sub>1.3</sub>. Tile drainage

The nutrient input from tile drainage will be calculated for every studied catchment from the product of the drained area, drainage water volume and the average nutrient concentrations.

With the following equations, the drain water flow is calculated according to KRETZSCHMAR (1977) on the basis of the summer and winter precipitation. From this, the drainage outflow of 50% of winter and 10% of the summer precipitation is obtained:

$$q_{DR} = 0,5 \cdot N_{WI} + 0,1 \cdot N_{SO}$$

with  $q_{DR}$  = specific drain water flow [mm/(m<sup>2</sup>· a)],

$N_{WI}$  = average precipitation in the winter half year [mm/(m<sup>2</sup>· a)] and

$N_{SO}$  = average precipitation in the summer half year [mm/(m<sup>2</sup>· a)].

This approach takes into account the regional different distribution of rainfall and runoff.

The P-concentration in the catchments was calculated as an area-weighted mean on the basis of the values in Table and the estimated areas of sandy soils, loams, fen and bog soils according to the soil survey map of Germany (BÜK 1000):

Soil type	Term	$C_{DR_p}$ [mg P/l]
Sandy soils	$C_{DRSP}$	0.20
Loam	$C_{DRLP}$	0.06
Fen soils	$C_{DRNMP}$	0.30
Bog soils	$C_{DRHMP}$	10.00

$$C_{DR_p} = \frac{C_{DRSP} \cdot A_{DRS} + C_{DRLP} \cdot A_{DRL} + C_{DRNMP} \cdot A_{DRNM} + C_{DRHMP} \cdot A_{DRHM}}{A_{DRS} + A_{DRL} + A_{DRNM} + A_{DRHM}}$$

with  $C_{DR_p}$  = drainage water phosphorus concentration [mg P/l],

$C_{DRSP}$  = drainage water phosphorus concentration for sandy soil [mg P/l],

$C_{DRLP}$  = drainage water phosphorus concentration for loamy soil [mg P/l],

$C_{DRNMP}$  = drainage water phosphorus concentration for fen soil [mg P/l],

$C_{DRHMP}$  = drainage water phosphorus concentration for bog soil [mg P/l],

$A_{DRS}$  = area of drained sandy soil [km<sup>2</sup>],

$A_{DRL}$  = area of drained loams [km<sup>2</sup>],

$A_{DRNM}$  = area of drained fen soil [km<sup>2</sup>] and

$A_{DRHM}$  = area of drained bog soil [km<sup>2</sup>].

The calculation of nitrogen concentration in drain water is based on the regionally differentiated N-surpluses (BACH ET AL., 1998). From the N-surpluses the potential nitrate concentration in leakage water is calculated according to FREDE & DABBERT (1998) which should correspond to the concentration in drainage water. It is assumed that the net mineralisation and net immobilisation in both studied time periods are negligibly low.

$$C_{DR_{NO3-N}} = \frac{(N_{\dot{U}LN} - DNR) \cdot AF \cdot 100}{SW}$$

with  $C_{DR_{NO3-N}}$  = nitrate concentration in drainage water [g N/l],  
 $N_{\dot{U}LN}$  = nitrogen surplus of agricultural areas [kg N/(ha· a)],  
 $DNR$  = denitrification rate [kg N/(ha· a)],  
 $AF$  = exchange factor and  
 $SW$  = leakage water quantity [l/(m<sup>2</sup>· a)].

#### B1.4. Groundwater

The P-concentration in the catchment areas was calculated on the basis of the area values of sandy soils, loamy soils, fen and bog soils as area weighted average for the agricultural land according to Equation:

$$C_{GWL_N_P} = \frac{C_{GWS_P} \cdot A_S + C_{GWL_P} \cdot A_L + C_{GWNM_P} \cdot A_{NM} + C_{GWHM_P} \cdot A_{HM}}{A_S + A_L + A_{NM} + A_{HM}}$$

with  $C_{GWL_N_P}$  = groundwater phosphorus concentration for agricultural land [mg P/l],  
 $C_{GWS_P}$  = groundwater phosphorus concentration for sandy soil [mg P/l],  
 $C_{GWL_P}$  = groundwater phosphorus concentration for loamy soil [mg P/l],  
 $C_{GWNM_P}$  = groundwater phosphorus concentration for fen soil [mg P/l],  
 $C_{GWHM_P}$  = groundwater phosphorus concentration for bog soil [mg P/l],  
 $A_S$  = area of sandy soil [km<sup>2</sup>],  
 $A_L$  = area of loamy soil [km<sup>2</sup>],  
 $A_{NM}$  = area of fen soil [km<sup>2</sup>] and  
 $A_{HM}$  = area of bog soil [km<sup>2</sup>].

In a second step, the average P concentrations in groundwater of particular catchments were calculated as an area weighted average from the P concentrations of agricultural and non-agricultural areas:

$$C_{GW_P} = \frac{C_{GWL_N_P} \cdot A_{LN} + C_{GW_{WAOF}_P} \cdot A_{WAOF}}{A_{LN} + A_{WAOF}}$$

with  $C_{GW_P}$  = phosphorus concentration in groundwater [mg P/l],  
 $C_{GW_{WAOF}_P}$  = groundwater phosphorus concentration for woodland and open areas [mg P/l],  
 $A_{LN}$  = agricultural area [km<sup>2</sup>] and  
 $A_{WAOF}$  = woodland and open area [km<sup>2</sup>].

The nitrate concentrations in groundwater can be calculated according to Equation

$$C_{GW_{NO3-N}} = \left( \sum_{i=1}^4 \frac{1}{1 + k_{Li} \cdot SW^{k2i}} \cdot \frac{A_{HG_i}}{A_{EZG}} \right) \cdot C_{SWPOT_{NO3-N}}^a$$

with  $A_{HG}$  = area of different hydrogeologically rock types [km<sup>2</sup>].  
 $k_1$  and  $k_2$  = model coefficients.  
 A value of 0.627 was determined for coefficient  $a$ .

$$C_{SWPOT_{NO_3-N}} = \frac{N_{UGES} \cdot AF \cdot 100}{SW}$$

with  $C_{SWPOT_{NO_3-N}}$  = potential nitrate concentration in leakage water for the total area with base flow [g N/m<sup>3</sup>],  
 $AF$  = exchange factor and  
 $SW$  = leakage water quantity [l/(m<sup>2</sup>· a)].

Following the determination of P- and N- groundwater concentrations, it is now necessary to estimate the quantity of the runoff component for every catchment which characterizes the sum of base flow and natural interflow to estimate the nutrient inputs by this pathway.

$$Q_{GW} = Q - Q_{DR} - Q_{RO} - Q_{URB} - Q_{AD}$$

with  $Q_{GW}$  = base flow and natural interflow [m<sup>3</sup>/s],  
 $Q$  = average runoff [m<sup>3</sup>/s],  
 $Q_{DR}$  = tile drainage flow [m<sup>3</sup>/s],  
 $Q_{RO}$  = surface runoff from non-paved areas [m<sup>3</sup>/s],  
 $Q_{URB}$  = surface runoff from urban areas [m<sup>3</sup>/s] and  
 $Q_{AD}$  = atmospheric input flow [m<sup>3</sup>/s].

## B<sub>2</sub>. Atmospheric deposition

The basis for the estimation of direct inputs into freshwaters by atmospheric deposition is the knowledge of the water surface area of a basin which is connected to the river system. The water areas will be determined from CORINE-land cover map. In addition, for the total water area, the flowing waters will be considered from the results of flow analysis according to BEHRENDT & OPITZ (1999) derived from BILLEN AT AL. (1995). After that, one can find out the area of flowing waters dependant on the catchment area according to the following:

$$A_W = A_{WSEE} + A_{WFGW} = A_{WCLC} + 0,001 \cdot A_{EZG}^{1,185}$$

where  $A_W$  = total water surface area [km<sup>2</sup>],  
 $A_{WSEE}$  = water surface area from land use map [km<sup>2</sup>],  
 $A_{WFGW}$  = surface area of flowing waters [km<sup>2</sup>],  
 $A_{WCLC}$  = water surface area from CORINE-Landcover [km<sup>2</sup>] and  
 $A_{EZG}$  = catchment area [km<sup>2</sup>].

Phosphorus and Nitrogen deposition is rarely measured and there is hardly any blanket coverage information available on P-and N deposition in German catchment areas. For the old German states, a P-deposition of 0.37 kg P/(ha· a) and a N deposition of 24 kg N/(ha· a) is used.

## B<sub>3</sub>. Urban areas

For the estimate of the nutrient inputs from urban areas, different pathways will be calculated separately and later amalgamated. The Figure that follows gives a general overview of the flows of materials in urban systems. From these, the inputs from unpaved urban areas are already

considered with the inputs via groundwater. In addition, inputs from impervious urban areas discharged via the combined sewer system to the waste water treatment plants are already contained in the point source inputs from municipal waste water treatment plants.

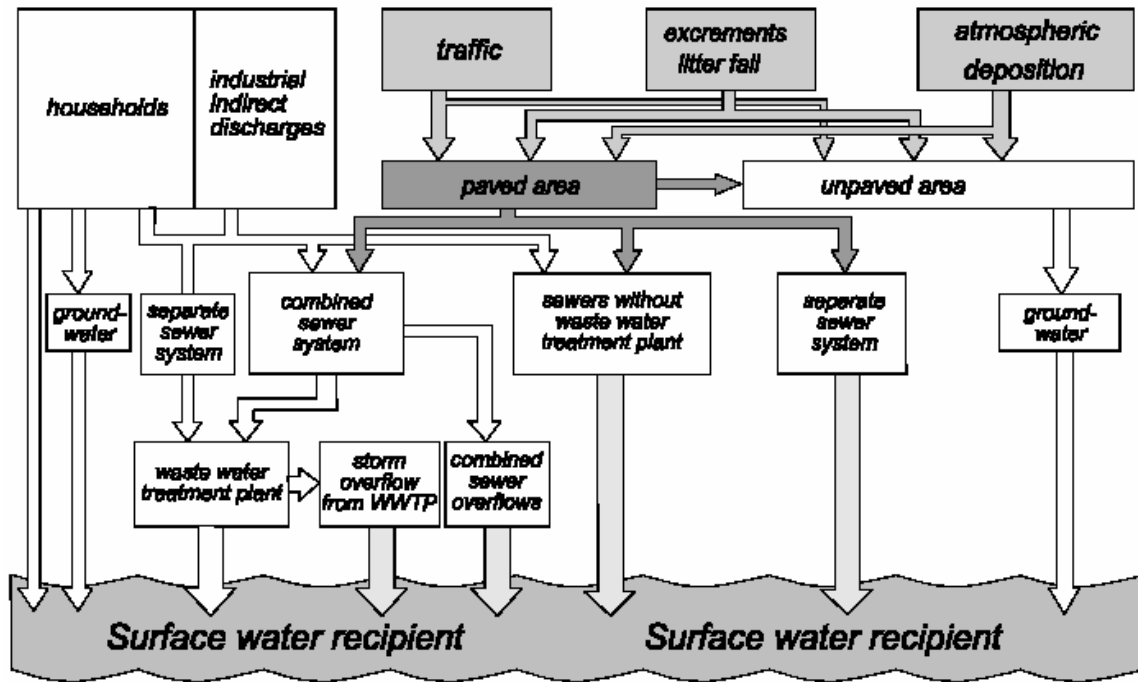

Figure 2: Input paths from urban areas

In this section, the methods for the quantification of remaining pathways will be described, which are:

- Inputs from households and impervious urban areas connected neither to a sewer nor a waste water treatment plant,
- Inputs from households and impervious urban areas via combined sewer overflows,
- Inputs from household and impervious urban areas connected to sewers but not to a waste water treatment plant and
- Inputs from impervious urban areas via a separate sewer system

$$A_{URBV} = u_1 (u_2 \cdot E_{DICHTE})^{u_3 - u_4 \cdot \log(u_2 \cdot E_{DICHTE})} \cdot A_{URB}$$

where  $A_{URBV}$  = impervious urban area [km<sup>2</sup>],  
 $A_{URB}$  = total urban area [km<sup>2</sup>],  
 $E_{DICHTE}$  = population density [E/km<sup>2</sup>] and  
 $u_1 - u_4$  = model coefficients.

$$a_{URBV} = 0,15 + 0,75 \cdot \frac{A_{URBV}}{A_{URB}}$$

where  $a_{URBV}$  = share of precipitation realized as surface runoff from impervious urban areas.

With the share of the precipitation realized as surface runoff from impervious urban areas and the yearly rainfall, the specific surface runoff can be estimated which is discharged from impervious urban areas during storm water events in all catchment areas:

$$q_{URBV} = a_{URBV} \cdot N_J$$

with  $q_{URBV}$  = specific surface runoff from impervious urban areas [l/(m<sup>2</sup>· a)] and  
 $N_J$  = annual precipitation [l/(m<sup>2</sup>· a)].

### 1. Nutrient inputs via separate sewers

In addition to atmospheric deposition, inputs through leaf-fall and animal excrement are yet to be estimated. We accept a value of 4 kg N/(ha· a) for these inputs. The specific N-input from the impervious areas will be estimated then using the equation

$$AS_{URBN} = 4 + N_{DEP}$$

where  $AS_{URBN}$  = specific N-input from impervious urban areas [kg N/(ha· a)] and  
 $N_{DEP}$  = atmospheric nitrogen deposition [kg N/(ha· a)].

The total phosphorus and nitrogen quantities discharged in every catchment area can be calculated by multiplication of the impervious urban area connected to separate sewer systems with the specific P- and N-inputs.

$$EUT_{N,P} = AS_{URBN,P} \cdot A_{URBVT} \cdot 100$$

where  $EUT_{N,P}$  = nutrient inputs via separate sewers [t/a] and  
 $A_{URBVT}$  = impervious urban area connected to separated sewer system [km<sup>2</sup>].

### 2. Nutrient inputs via combined sewer overflows

Combined sewer systems collect the input from households, indirect industrial inputs and rain-water runoff and bring these water to the waste water treatment plant in normal weather conditions. The layout of the combined sewer system and the waste water treatment plant is such that with normal rainfall, the mixed water mostly flows through the treatment plant. With storm water events when only a small fraction is stored, the quantity of water flowing through the treatment plant is in accordance with regulations. The quantity of water which is untreatable or water which does not enter treatment plants is then discharged to water bodies via combined sewer overflow or through a bypass at the treatment plant.

The total water quantity in the combined sewer system during the days of storm water events can be calculated with Equation

$$Q_{URBM} = q_{URBV} \cdot A_{URBVM} + Z_{NT} \cdot (E_{KA} \cdot q_E + a_{GEW} \cdot q_{GEW} \cdot 100 \cdot 86,4 \cdot A_{URB})$$

where  $Q_{URBM}$  = storm water runoff from combined sewer system [m<sup>3</sup>/s],  
 $A_{URBVM}$  = impervious urban area connected to combined sewer system [km<sup>2</sup>],  
 $Z_{NT}$  = effective number of storm water days,  
 $E_{KA}$  = number of inhabitants connected to combined sewer system,  
 $q_E$  = daily wastewater output per inhabitant [l/(E· d)],  
 $Q_{GEW}$  = industrial-commercial wastewater [m<sup>3</sup>/s],  
 $a_{GEW}$  = proportion of total urban area in commercial use and  
 $q_{GEW}$  = specific runoff from commercial areas [l/(ha· s)].

A value of 130 l/(E· d) will be used for  $q_E$ . For the calculation of the quantity of commercial waste water, MOHAUPT ET AL. (1998) give a figure of 0.5 l/(ha· s) for  $q_{GEW}$  for 10 hours per day based on a total urban area in commercial use ( $a_{GEW}$ ) of 0.8% or in other words 432 m<sup>3</sup>/(ha· d).

The discharge rate of a combined sewer system varies in relation to the removal grade, i.e. the retention volume of the combined sewer. The retention or storage volume holds back a fraction of the waste water during the storm water event and retards the flow to the treatment plant. One can estimate the discharge rate according to MEIBNER (1991) from Equation

$$RE = \frac{\frac{4000 + 25 \cdot q_R}{0,551 + q_R}}{V_S + \frac{36,8 + 13,5 \cdot q_R}{0,5 + q_R}} - 6 + \frac{N_J - 800}{40}$$

where RE = discharge rate of combined sewer overflows [%],  
 $q_R$  = rainfall runoff rate [l/(ha · s)],  
 $V_S$  = storage volume [m<sup>3</sup>] and  
 $N_J$  = annual precipitation [l/(m<sup>2</sup> · a)].

From this, MEIBNER (1991) and BROMBACH & MICHELBAACH (1998) give a retention volume of 23.3 m<sup>3</sup>/ha with 100% rate of discharge. With a removal grade of 10% there is no retention volume. According to HAMM ET AL. (1991), a rate of discharge of 25% corresponds to a retention volume of ca. 6 m<sup>3</sup>/ha. In their studies of the Lake Constance catchment area, BROMBACH & MICHELBAACH (1998) estimated an average removal grade of 50% and a mean rainfall runoff rate of 1 l/(s · ha)

The nutrient concentration in combined sewers during overflow events can be calculated with the previously given assumptions from:

$$C_{M,N,P} = \frac{((AG_{E,N,P} \cdot E_{KA} + C_{GEW,N,P} \cdot Q_{GEWM}) \cdot Z_{NT} + AS_{N,P} \cdot A_{URBVM} \cdot 100) \cdot \frac{RE}{100}}{Q_{URBM}}$$

where  $C_{M,N,P}$  = nutrient concentration in combined sewers during overflow [g/m<sup>3</sup>],  
 $AG_{E,N,P}$  = inhabitant-specific N- or P-output [g/(E · d)],  
 $C_{GEW,N,P}$  = nutrient concentration in commercial wastewater [g/m<sup>3</sup>] and  
 $Q_{GEWM}$  = runoff from commercial areas connected to combined sewers [m<sup>3</sup>/d].

The total input of nutrients caused by combined sewer overflows in a catchment area can be calculated on the basis of the Equation that follows:

$$EUM_{N,P} = C_{M,N,P} \cdot RE \cdot Q_{URBM}$$

where  $EUM_{N,P}$  = nutrient input via combined sewer overflows [t/a].

### 3. *Nutrient inputs via sewers not connected to wastewater treatment plants*

The waste water statistics identify people connected to water treatment plants and also the proportion of population connected to a sewer system but not to a waste water treatment plant. In the following, it is assumed that the proportion of urban areas which are connected to a sewer but not to a waste water treatment plant corresponds to the proportion of people only connected to a sewer system. Regarding the inputs of materials, these areas can be considered in the same way as the areas with separate sewer systems (see above). The same is assumed for the specific values of the nutrient inputs from these areas.

In addition, the nutrient inputs from the inhabitants who have only a sewer connection must be considered. The proportion of human nutrient output transported mainly as particulate material to waste water treatment plants is already described. For the dissolved fraction it is assumed that this proportion is fully supplied to the sewer system. The total nutrient input along this pathway will then be calculated according to the Equation

$$EUK_{N,P} = AS_{N,P} \cdot A_{URBK} \cdot 100 + E_{URBK} \cdot AG_{ES_{N,P}} \cdot 0,365 + C_{GEW_{N,P}} \cdot Q_{GEWK}$$

where  $EUK_{N,P}$  = nutrient input via impervious urban areas and from inhabitants connected only to sewers [t/a],

$A_{URBK}$  = urban area connected only to sewers [km<sup>2</sup>],

$E_{URBK}$  = inhabitants connected only to sewers,

$Q_{GEWK}$  = annual runoff from commercial areas only connected to sewers [m<sup>3</sup>/s]

and

$AG_{ES_{N,P}}$  = inhabitant specific output of dissolved nutrients [g/(E·d)].

The specific human dissolved nutrient outputs were 1.05 g P/(E·d) and 9 g N/(E·d)

### 4. *Nutrient inputs via households connected neither to wastewater treatment plants or sewers*

Up to now, only the proportion of people and urban areas connected to sewers have been considered. Inputs into water bodies may also come from people or areas connected neither to sewers nor waste water treatment plants. For the nutrient inputs from these areas, the following applies

$$EUN_{N,P} = (100 - R_{B_{N,P}}) \cdot (AS_{N,P} \cdot A_{URBN} \cdot 100 + E_{URBN} \cdot AG_{ES_{N,P}} \cdot 0,365 \cdot (100 - K_{ABF}))$$

where  $EUN_{N,P}$  = nutrient input via inhabitants and impervious urban areas connected neither to sewers nor to wastewater treatment plants [t/a],

$R_{B_{N,P}}$  = nutrient retention in soil [%],

$A_{URBN}$  = impervious urban area connected neither to a sewer nor to a wastewater treatment plant [km<sup>2</sup>],

$E_{URBN}$  = inhabitants connected neither to sewers nor to wastewater treatment plants,

$AG_{ES_{N,P}}$  = inhabitant specific output of dissolved nutrients [g P/(E·d)] and

$K_{ABF}$  = proportion of dissolved human nutrient output transported to wastewater treatment plants [%].

### C. MODEL INPUT

- River/catchment name/gauge station names
- Catchment area (km<sup>2</sup>): Mean slope (%), Tile drained area (%)
- Landuse area (km<sup>2</sup>)
- Statistics of municipals: Inhabitants, arable area (km<sup>2</sup>)
- Urban systems: Inhabitants connected to WWTP or/and sewer, sewer flow length, total discharge of P, N from WWTP per catchment
- Hydrogeological type areas (km<sup>2</sup>) defined by soil, porosity, permeability, depth of groundwater
- Mean soil loss (t\*(ha\*a)), proportions of soil type on total area (km<sup>2</sup>),
- Nitrogen content in topsoil (%), clay content (%)
- Precipitation (mm/m<sup>2</sup>), atmospheric deposition (gN/m<sup>2</sup>), mean evaporation (mm/a)
- Nitrogen surplus (kg/(ha\*a))

## D. MODEL OUTPUT

The final output is an estimate of annual nutrient load at the river outlet (emissions minus retention and loss within the river) for its subcatchment and for the whole basin area.

## E. FIRST APPLICATION OF MONERIS IN NECKAR BASIN

The reference year for the first application of the model is the year 2000. The model was run for the whole Neckar basin. The basin was divided in 42 subcatchments from 134 Km<sup>2</sup> to 505 Km<sup>2</sup>.

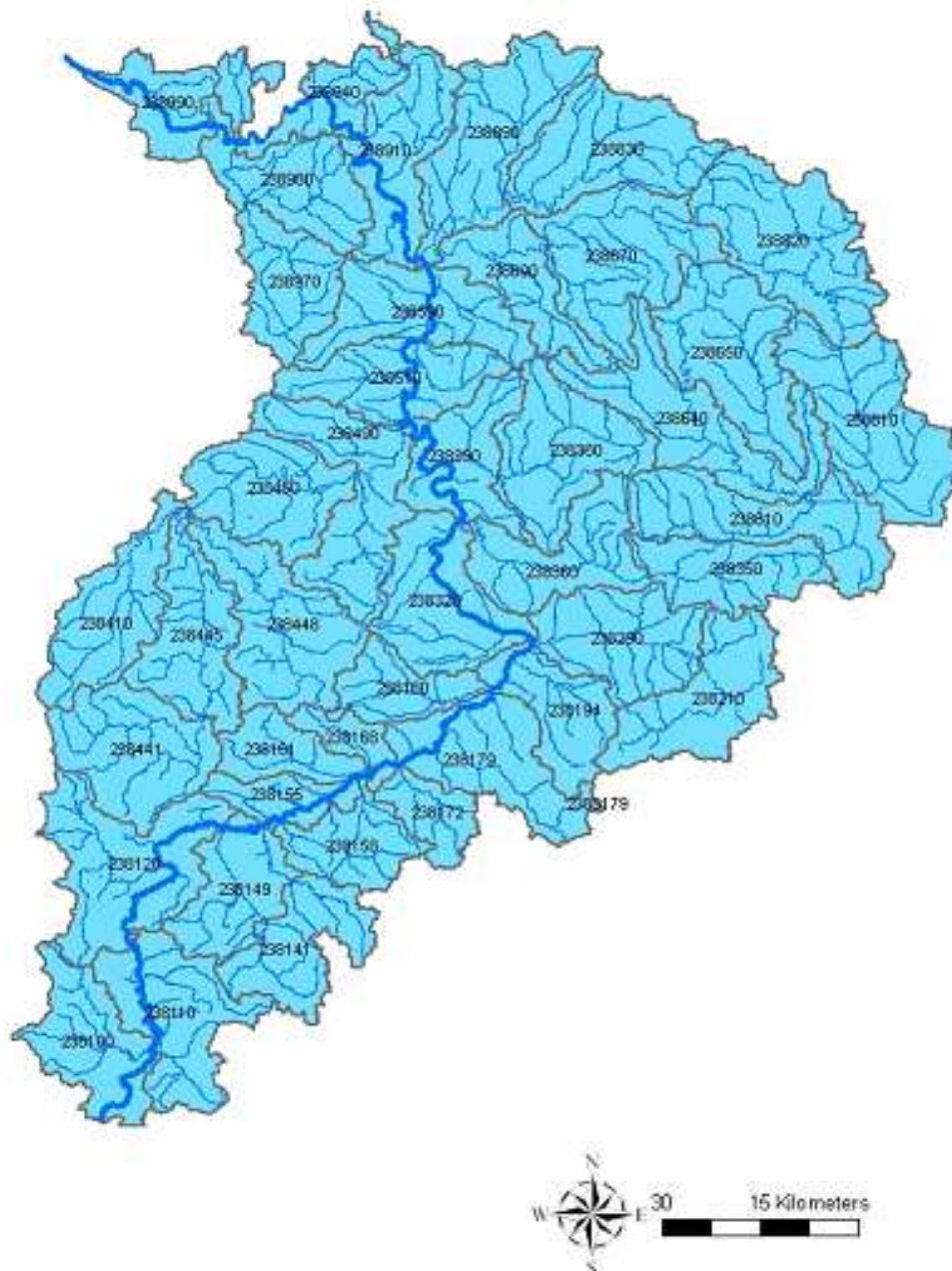

Figure 3: Neckar basin

Some of the model outputs for the Neckar basin are shown in the below graphs.

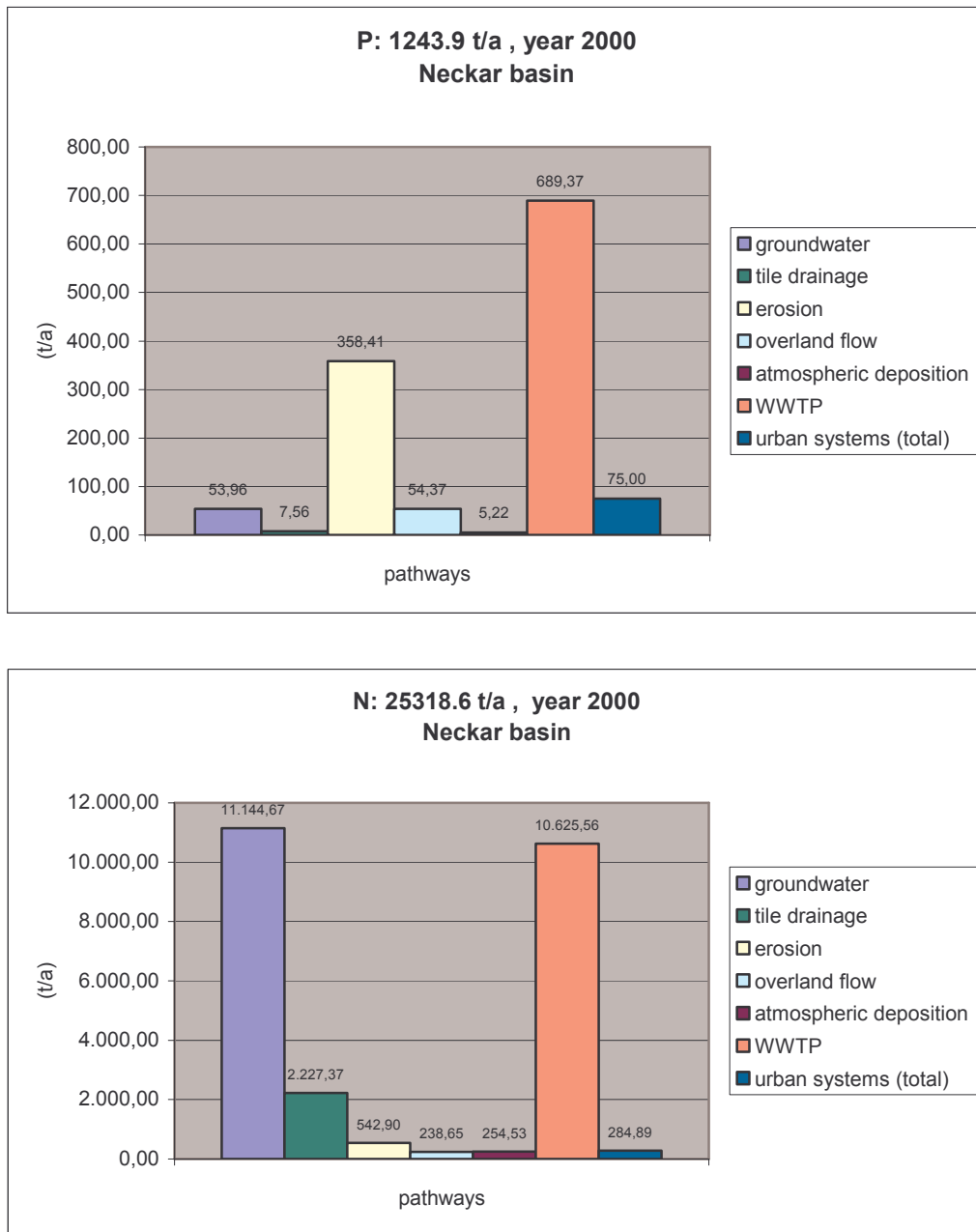

Figure 4: Nutrient emissions at the outlet of the Neckar basin for the reference year 2000

## **F. Application of MONERIS with Excel**

The method used in this Excel files refers basically to the report “Nutrient Emissions into River Basins of Germany” (Behrendt et. al, 2000). It has been applied to many catchments in Europe.

In order to make the application of MONERIS with EXCEL as flexible as possible we separated the input data (BasicInfo.xls), the pathways and a file in which all results are collated and summed up (MONERIS.xls).

Up to now MONERIS can calculate nutrient emissions from up to 300 catchments. Please ask Mr. Behrendt, Mr. Venohr for an extended version if you want to do this calculations for more than 300 catchments.

The complete set consists of following files:

- 1 BASICINFO
- 2 ATMOSPHERIC DEPOSITION
- 3 OVERLAND FLOW
- 4 EROSION
- 5 TILE DRAINAGE
- 6 GROUNDWATER
- 7 URBAN SYSTEMS
- 8 POINT SOURCES (WWTP)
- 9 BACKGROUND
- 10 SURPLUS
- 11 MONERIS

## **General remarks for the work with this MONERIS EXCEL Version**

All data needed for the calculation are collated in the BASICINFO file. The data always refer to the net catchments<sup>1</sup>. Like this all calculations are made for the net catchments first and later on summed up for the total catchment to enable a comparison with the measured nutrient load in the rivers.

The files are linked in several ways. Like this you have to be carefully with deleting or displacing cells or columns. Following should help to avoid loosing links:

- All files have to stay in the folder MONERIS.
- When deleting or adding columns to BASICINFO all other files should be opened. The links than will be updated automatically.
- When working with cut & paste, the links will be changed from the origin location to the new location. You can avoid loosing links by keeping all other files closed. In general it's better to work with copy & paste.
- The file MONERIS is linked only to the sheet “results” of the different pathways. When changing method, content or structure of the sheets you only have to make sure not to change the structure of the sheet “results”. If you keep the filename and the sheet structure it is no problem to exchange the whole file, for example to test different methods or different sets of parameters.

---

<sup>1</sup> Net catchments means the catchment area of the river course between two monitoring stations.

## MONERIS

In this file the results of the different pathways are summed up and displayed in the sheet “report”. It is distinguished between the results of the net catchments and those from the total catchments. There also is the possibility to do these calculations for all catchments or only for those located within an artificial subdivision, for example within an administrative area. These catchments can be selected in BASICINFO/generals/column H.

## BASICINFO

The colours in this file have following meanings:

- Yellow: there are links from the pathway files to these cells. They are necessarily needed for the calculations.
- Light blue: these cells are needed for intermediate calculations
- Red letters: these cells are containing equations and do not have to be filled in by the user
- On sheet “generals” you’ll find a button to refresh the flow net equation. This button starts a macro, which copies the equation from these columns to all columns where the equations are needed; also the cell links are adapted. You only have to do this once. With this macro only 300 catchments can be considered! When building the flow net equation please use this structure:

A	B	C	D	E
Name	Spring/ flushed catchment	Catchment area	Area sub catchment	Positive equation
1	Q	5	5	= D1
2	D	10	5	= D2+E1
3	Q	8	8	= D3
4	D	25	7	= D4+E3+E2

**Not like this!**

= sum(D1:D4)

## THE QUAL2K MODEL

# 1. Background of the model QUAL2K

Water quality standards are implemented through a process of calculating Waste Load Allocations (WLAs) and/or Total Maximum Daily Loads (TMDLs). Ultimately Permit Limits are developed based on the calculated WLAs and TMDLs. Many of these required calculations are performed with computer simulation models. Either steady-state or dynamic modelling techniques may be used.

QUAL2K (Chapra, S.C. and Pelletier, G.J. 2003) is a 1-D stream/river water quality model that is intended to represent a modernized version of the QUAL2E model (U.S. EPA 600/3-87/007, Brown and Barnwell 1987).

QUAL2K is similar to QUAL2E in the following respects:

- One dimensional. The channel is well mixed vertically and laterally.
- Steady state hydraulics. Non-uniform, steady flow is simulated.
- Diurnal heat budget. The heat budget and temperature are simulated as a function of meteorology on a diurnal time scale.
- Diurnal water-quality kinetics. All water quality variables are simulated on a diurnal time scale.
- Heat and mass inputs. Point and non-point loads and abstractions are simulated.

The QUAL2K (Q2K) framework includes the following new elements:

- Software Environment and Interface. Q2K is implemented within the Microsoft Windows environment. It is programmed in the Windows macro language: Visual Basic for Applications (VBA). Excel is used as the graphical user interface.
- Q2K uses unequally spaced reaches. In addition, multiple loadings and abstractions can be input to any reach.
- Q2K uses two forms of carbonaceous BOD (slow CBOD and fast CBOD) to represent organic carbon. In addition, non-living particulate organic matter (detritus) is simulated.
- Sediment-water fluxes of dissolved oxygen and nutrients are simulated.
- The model explicitly simulates attached bottom algae.
- Both alkalinity and total inorganic carbon are simulated. The river's pH is then simulated based on these two quantities.
- A generic pathogen is simulated. Pathogen removal is determined as a function of temperature, light, and settling.

## 2. Model concept

### 2.1 Segmentation

The conceptual representation of a stream used in the QUAL2K formulation is river that has been divided into a number of unequally spaced reaches or computational elements equivalent to finite difference elements (Figure1).

For each computational element, a hydrologic balance in terms of flow, a heat balance in terms of temperature, and a mass balance in terms of constituents concentration is written. The model presently simulates the main stem of a river. In addition, multiple loadings and abstractions can be input to any reach. Tributaries are not modelled explicitly, but can be represented as point sources.

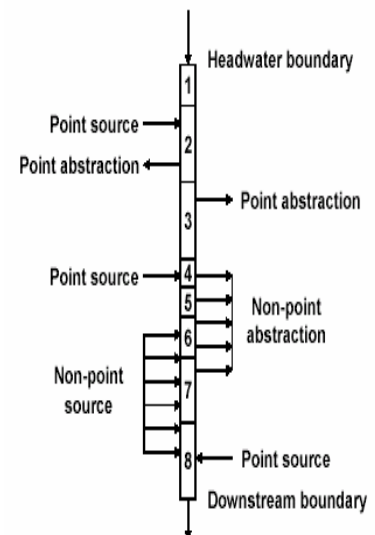

Figure 1: QUAL2K segmentation scheme

## 2.2 Flow Balance

A steady-state flow balance is implemented for each model reach:

$$Q_i = Q_{i-1} + Q_{in,i} - Q_{ab,i}$$

where  $Q_i$  = outflow from reach  $i$  into reach  $i + 1$  [ $m^3/d$ ],  $Q_{i-1}$  = inflow from the upstream reach  $i - 1$  [ $m^3/d$ ],  $Q_{in,i}$  is the total inflow into the reach from point and nonpoint sources [ $m^3/d$ ], and  $Q_{ab,i}$  is the total outflow from the reach due to point and nonpoint abstractions [ $m^3/d$ ].

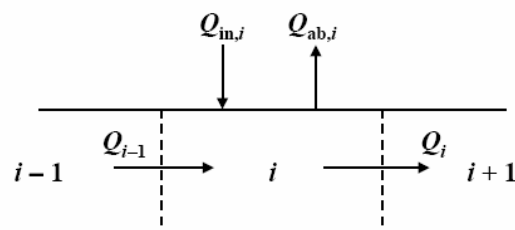

Figure 2: Reach flow balance

## 2.3 Hydraulic Characteristics

QUAL2K simulates changes in flow conditions along the stream by computing a series of steady-state water surface profiles. Once the outflow for each reach is computed, the depth and velocity are calculated in one of three ways: weirs, rating curves, and Manning equations.

- If a weir exists then:  $Q_i = 1.83 * B_i * H_h^{3/2}$ , where  $Q_i$  is the outflow from the reach upstream of the weir in  $m^3/s$ ,  $B_i$  = the width of reach  $i$  [m] and  $H_h$  = the head above the weir [m].

The head above the weir is then:  $H_h = \left( \frac{Q_i}{1.83 * B_i} \right)^{2/3}$

and the depth of the reach upstream of the weir is:  $H_i = H_w + H_h$ , where  $H_w$  = the height of the weir above the river bed.

- Power equations can be used to relate mean velocity and depth to flow:

$U = aQ^b$  and  $H = \alpha Q^\beta$ , where  $\alpha, b, \alpha, \beta$  are empirical coefficients determined from velocity-discharge and stage-discharge rating curves.

Each reach is idealized as a trapezoidal channel. Under conditions of steady flow, the Manning equation can be used to express the relationship between flow and depth as:

$Q = \frac{S_0^{1/2} * A_c^{5/3}}{n * P^{2/3}}$ , where  $S_0$  = bottom slope [m/m],  $n$  = the Manning roughness coefficient,  $A_c$  = the cross-sectional area [m<sup>2</sup>], and  $P$  = the wetted perimeter [m].

The cross-sectional area of a trapezoidal channel is computed as:  $A_c = [B_0 + 0.5 * (s_{s1} + s_{s2}) * H] * H$ , where  $B_0$  = bottom width [m],  $s_{s1}$  and  $s_{s2}$  = the two side slopes as shown in [m/m], and  $H$  = reach depth [m].

The wetted perimeter is computed as:  $P = B_0 + H\sqrt{s_{s1}^2 + 1} + H\sqrt{s_{s2}^2 + 1}$

After substituting the last two equations, the below equation can be solved iteratively for depth:

$$H_{k+1} = \frac{(Q_n)^{3/5} \left( B_0 + H\sqrt{s_{s1}^2 + 1} + H\sqrt{s_{s2}^2 + 1} \right)^{2/5}}{S_0^{3/10} [B_0 + 0.5(s_{s1} + s_{s2})H]}$$

where  $k = 0, 1, 2, \dots, n$ , where  $n$  = the number of iterations. The method is terminated when the estimated error falls below a specified value of 0.001%.

The calculated stream flow rate, velocity, cross-sectional area and water depth serve as a basis for determining the heat and mass fluxes into and out of each computational element (reach) due to flow.

## 2.4 Heat Balance

The heat balance (Fig.3) takes into account heat transfers from adjacent reaches, loads, abstractions, the atmosphere, and the sediments. A heat balance can be written for reach  $i$  as:

$$\begin{aligned} \frac{dT_i}{dt} = & \frac{Q_{i-1}}{V_i} T_{i-1} - \frac{Q_i}{V_i} T_i - \frac{Q_{ab,i}}{V_i} T_i + \frac{E'_{i-1}}{V_i} (T_{i-1} - T_i) + \frac{E'_i}{V_i} (T_{i+1} - T_i) \\ & + \frac{W_{h,i}}{\rho_w C_{pw} V_i} \left( \frac{m^3}{10^6 \text{ cm}^3} \right) + \frac{J_{h,i}}{\rho_w C_{pw} H_i} \left( \frac{m}{100 \text{ cm}} \right) + \frac{J_{s,i}}{\rho_w C_{pw} H_i} \left( \frac{m}{100 \text{ cm}} \right) \end{aligned}$$

where  $T_i$  = temperature in reach  $i$  [°C],  $t$  = time [d],  $E'_{i-1}$  = the bulk dispersion coefficient between reaches  $i$  and  $i + 1$  [m<sup>3</sup>/d],  $W_{h,i}$  = the net heat load from point and non-point sources into reach  $i$  [cal/d],  $\rho_w$  = the density of water [g/cm<sup>3</sup>],  $C_{pw}$  = the specific heat of water [cal/(g °C)],  $J_{h,i}$  = the air-water heat flux [cal/(cm<sup>2</sup> d)], and  $J_{s,i}$  = the sediment-water heat flux [cal/(cm<sup>2</sup> d)].

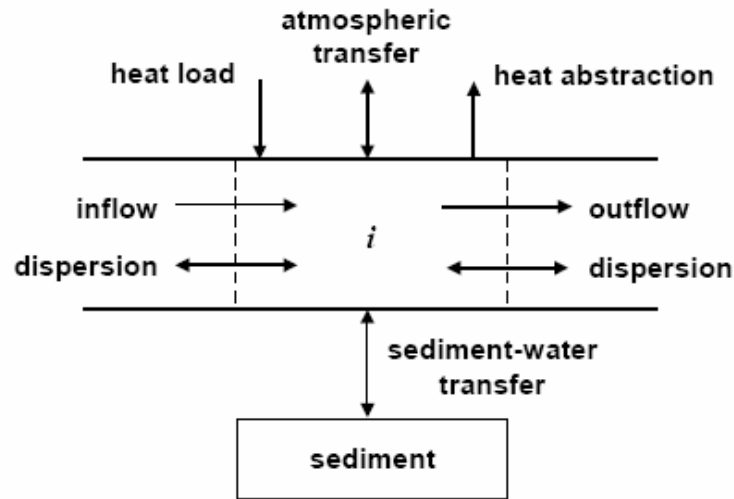

Figure 3: Reach heat balance

## 2.5 Mass Balance

Both advective and dispersive transport processes are considered in the mass balance. Mass is gained or lost from the reach by transport processes, wastewater discharges and withdrawals. Mass can also be gained or lost by internal processes such as release of mass from benthic sources or biological transformations.

Table 1: Model state variables

Variable	Units
Conductivity	μmhos
Inorganic Suspended Solids (ISS)	mg/l
Dissolved Oxygen	mg/l
CBOD	μg/l
Dissolved Organic Nitrogen	μg/l
NH4-Nitrogen	μg/l
NO3-Nitrogen	μg/l
Dissolved Organic Phosphorus	μg/l
Inorganic Phosphorus	μg/l
Phytoplankton	μg/l
Detritus	mg/l
Pathogen	cfu/100 mL
Alkalinity	mgCaCO <sub>3</sub> /L
pH	s.u.
Bottom algae	g/m <sup>2</sup>

For all except the bottom algae, a general mass balance (Fig.4) for a constituent (Table 1) in a reach is written as:

$$\frac{dc_i}{dt} = \frac{Q_{i-1}}{V_i} c_{i-1} - \frac{Q_i}{V_i} c_i - \frac{Q_{ab,i}}{V_i} c_i + \frac{E'_{i-1}}{V_i} (c_{i-1} - c_i) + \frac{E'_i}{V_i} (c_{i+1} - c_i) + \frac{W_i}{V_i} + S_i$$

where  $W_i$  = the external loading of the constituent to reach  $i$  [g/d or mg/d], and  $S_i$  = sources and sinks of the constituent due to reactions and mass transfer mechanisms [g/m<sup>3</sup>/d or mg/m<sup>3</sup>/d].

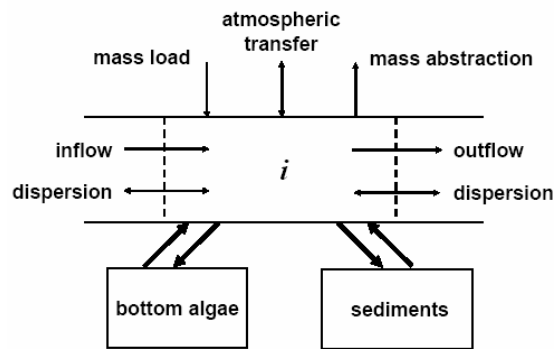

Figure 4: Reach mass balance

In each reach, the model computes the major interactions between up to 15 state variables (Table 1). The model uses a finite-difference solution of the advective-dispersive mass transport and reaction equations and it specifically uses a special steady-state implementation of an implicit backward difference numerical scheme, which gives the model an unconditional stability (Walton and Webb, 1994).

### 3. Model Input

The input data are shown in Table 2. The river flow, water temperature and hourly concentration of the state variables are the input data required at the headwater of the simulated river. For each of the system reach the hydraulic and the meteorological data tabulated below are required. Also, information about the point and diffuse sources that enter or leave the river are essential.

Table 2: Model Input

Headwater	Reach-Hydraulics	Reach-Meteorology	Point/Diffuse Sources
Flow; Water temperature; Hourly concentration of the water quality state variables (Table 1)	Reach length;  Elevation of reach upstream & downstream ;  Downstream latitude/longitude (0 , ' , " );  Bottom width, side slope, channel slope, Manning coefficient;  If known: Weir height, prescribed dispersion (downstream) prescribed reparation, bottom algae coverage, bottom SOD coverage, prescribed SOD, prescribed CH <sub>4</sub> flux, prescribed NH <sub>4</sub> flux, prescribed Inorg. Pflux	Hourly air temperature;  Hourly dewpoint temperature;  Wind speed ;  Hourly cloud cover shade;  Integrated hourly effective shade (fraction of solar radiation that is blocked because of shade from topography & vegetation)	Name and location of the point source or abstraction enters or leaves the river;  Location of the upstream and downstream kilometres over which the diffuse source or abstraction enters or leaves the river;  Point/diffuse source inflows and outflows (m <sup>3</sup> /s)  Temperature and water quality state variables concentrations of the point/diffuse source inflow

The model QUAL2K is forced by some model rate parameters: Stoichiometry of plant and detrital matter; rate parameters for inorganic suspended solids, oxygen, oxygen reaeration, CBOD, organic N, ammonium, nitrate, organic P, phytoplankton, bottom algae, detritus, pathogens and pH.

And by light and heat parameters: Photosynthetically available radiation, background light extinction, linear chlorophyll light extinction, nonlinear chlorophyll light extinction, inorganic suspended solids light extinction, detritus light extinction, atmospheric attenuation model for solar, atmospheric turbidity coefficient, atmospheric transmission coefficient, atmospheric longwave emissivity model, wind speed function for evaporation and air convection/conduction.

Recommended values of the above parameters are given in the user-manual.

## 4. Model Output

A series of worksheets that present tables of numerical output are generated by QUAL2K.

1. The hydraulics summary worksheet contains flows, velocities, travel time, depths, and cross-sectional areas along each reach;
2. The temperature output worksheet summarizes the mean, max. and min. temperature output for each model reach;
3. The WQ Output, WQ Min. & ,WQ Max worksheets summarize the mean, minimum and maximum concentration of the state variables for each model reach;
4. The Sediment Fluxes worksheet summarizes the fluxes of oxygen and nutrients between the water and the underlying sediment compartment for each model reach;
5. The Diel Output Worksheet displays temperature and concentration of the state variables against time (hr).

QUAL2K displays a series of charts that plot the model output and data versus distance (km) and time of day (in hours) for model outputs.

## 5. Validation

Known values of the below parameters at specific distance (km) along the river are used as control data for validating the model:

- Hydraulic characteristics (Q,H,U,t<sub>travel</sub>)
- Minimum and maximum daily Temperature
- Minimum and maximum daily concentrations of the water quality state variables
- Mean daily concentrations of the water quality state variables and other concentrations and fluxes (if known), such as: bottom algae, total nitrogen-data, total phosphorus-data, total suspended solids-data, NH<sub>3</sub> (unionized ammonia)-data, % saturation-data, SOD-data, sediment ammonium flux, sediment methane flux, sediment inorganic phosphorus flux, ultimate carbonaceous BOD, total organic carbon

## 6. Application of QUAL2K to the River Neckar

In general there is high data density and availability but in some thematic areas (such as water quality measurements highly resolved in time and point pollution loads from waste water treatment plants) data assembling is time consuming because they are not yet or insufficiently digitalized. This fact hinders the calibration and validation of the water quality model QUAL2K at the entire basin scale. Therefore the lower part of the River Neckar, from Hofen to Mannheim, where there is better data coverage was selected for model calibration and validation.

### 6.1 Water quality and hydro-meteorological data

Along the River Neckar there are 14 water quality stations (Figure 5). The data from these stations were obtained by LFU (Landesanstalt für Umweltschutz Baden-Württemberg) (Table 3). Hydro-meteorological data including discharge, air temperature, wind speed, dew point temperature and solar radiation on an hourly basis for the years 1988-2003 were collected by LFU stations (Figure 5).

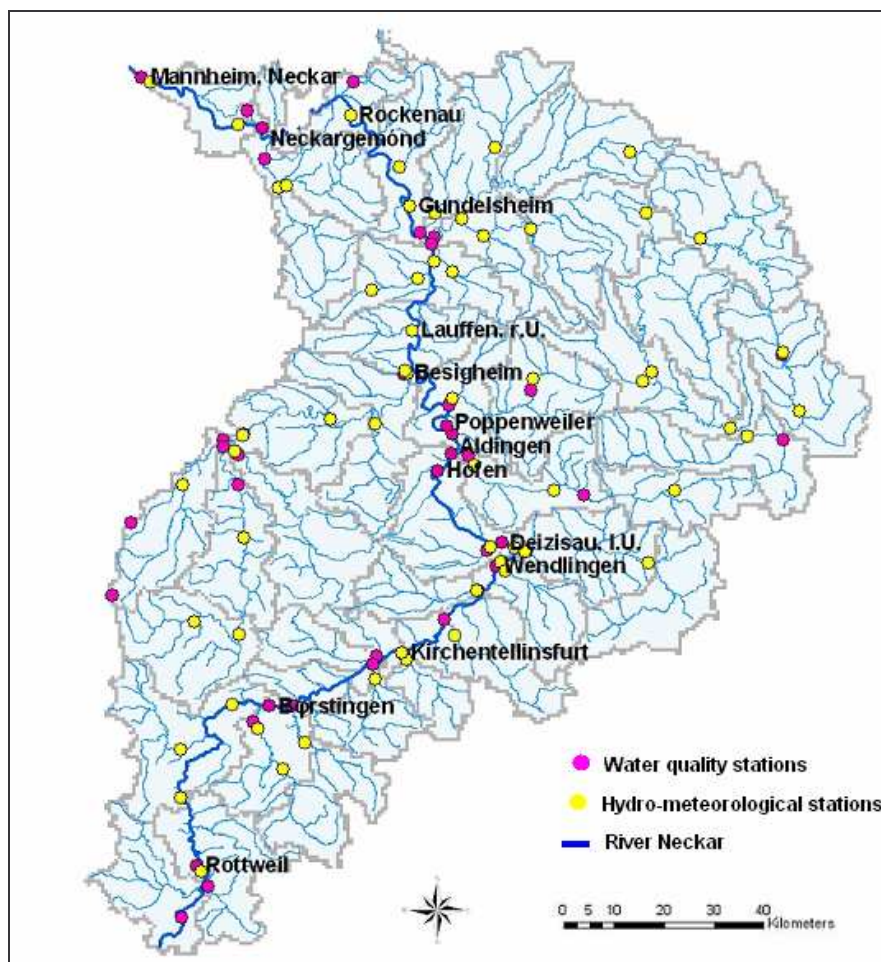

Figure 5: Water quality and hydro-meteorological stations (LFU)

Table 3: Water quality stations and data availability (LFU)

Station	Water quality variables	Temporal resolution
Wendlingen Hofen Aldingen Poppenweiler Pleidelsheim	Water temperature; Dissolved Oxygen; Conductivity; pH	Hourly data from 1/10/84 to 4/2/05
Besigheim Kochendorf FM Gundelsheim Rockenau Neckargemond Mannheim	N_anorg., ISS, CBOD, N_NH <sub>4</sub> , N_NO <sub>2</sub> , N_NO <sub>3</sub> , NH <sub>3</sub> , TP and detritus	Data on a random day of each month (1972-2002)
Schwenningen Börstingen Kirchentellinsfurt Deizau Lauffen	Water temperature, Dissolved Oxygen, Conductivity, pH, N_anorg., ISS, CBOD, N_NH <sub>4</sub> , N_NO <sub>2</sub> , N_NO <sub>3</sub> , NH <sub>3</sub> , TP and detritus	Data on a random day of each month (1972-2002)

The tributaries of the River Neckar are simulated as point sources. Their water quality and hydrometeorological data are taken from gauges located at the meeting point of each tributary with the River Neckar. Multiple loads of point and diffuse sources data are taken from MONERIS and statistical data (Statistisches Landesamt Baden-Württemberg, Stuttgart).

## 6.2 Geometric data

The lower Neckar (200km) is influenced by weirs. For this part of the river cross sections every 100m were provided by Matthias Schneider (sje). Water surface profiles were obtained by processing the cross sections. The hydraulic parameters for the Manning formula and weir formula were taken from these profiles.

## 6.3 Point and diffuse sources data

Point sources include point pollution loads from wastewater treatment plants (WWTPs) and water extractions along the River Neckar, loadings of its tributaries to the main stem and loadings of Moneris areas with an outlet to the River Neckar. Diffuse sources include loadings of Moneris areas that contain parts of the river Neckar.

## 6.4 Missing data

There is currently no data available on diffuse sources, water extractions and point pollution loads from WWTPs (see Table 2 for details). Also, there is a need for water quality measurements highly resolved in time (hourly) at the headwater of the River Neckar (Schwenningen).

## 6.5 First application of the model to the lower Neckar

The part of the River Neckar from Hofen to Mannheim was selected for model calibration and validation, since there is better data coverage for this lower part of the river (Figure 6).

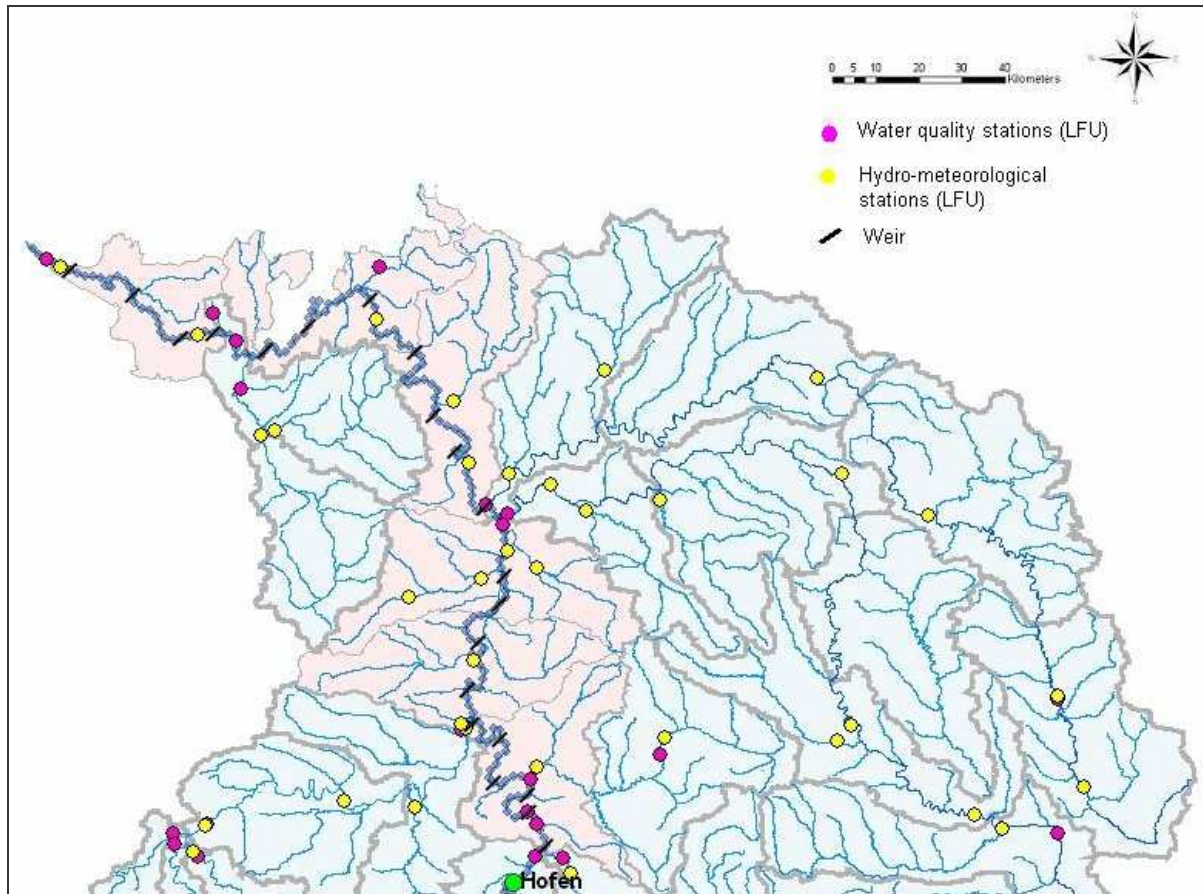

Figure 6: Segmentation of the simulated river

The model was first tested in some simple cases of flow in channels with uniform cross section, constant slope and constant flow rate. In these special cases the hydraulic output (water depth) may be analytically computed and the model accurately reproduces the analytical solution.

In the case of a rectangular channel, under conditions of steady flow, the Manning equation can be used to express the relationship between flow and depth as:

$$Q = \frac{1}{n} * (bh) * \left( \frac{b * h}{2b + h} \right)^{2/3} * S_0^{1/2} \quad (1)$$

where Q: flow (m<sup>3</sup>/s)  
 n: Manning roughness coefficient  
 b: bottom width (m)  
 h: water depth (m)  
 S<sub>0</sub>: channel slope (m/m)

Equation 1 can be solved iteratively for water depth:

$$h_{k+1} = \left( \frac{Q * n}{\sqrt{S_0}} \right)^{0.6} * \frac{(b + 2h)^{0.4}}{b} \quad (2)$$

where  $k = 0, 1, 2, \dots, n$ , where  $n$  = the number of iterations.

The method is terminated when the estimated error falls below a specified value of 0.001%.

The estimated error is calculated as:  $\varepsilon = \left| \frac{h_{k+1} - h_k}{h_{k+1}} \right| * 100\%$  (3)

Equation 2 was solved iteratively for a rectangular channel (Figure 7) with  $b = 4\text{m}$ ,  $S_0 = 0.001$ ,  $n = 0.02$  and  $Q = 10\text{m}^3/\text{s}$  and concluded to  $h = 1.68\text{ m}$ .

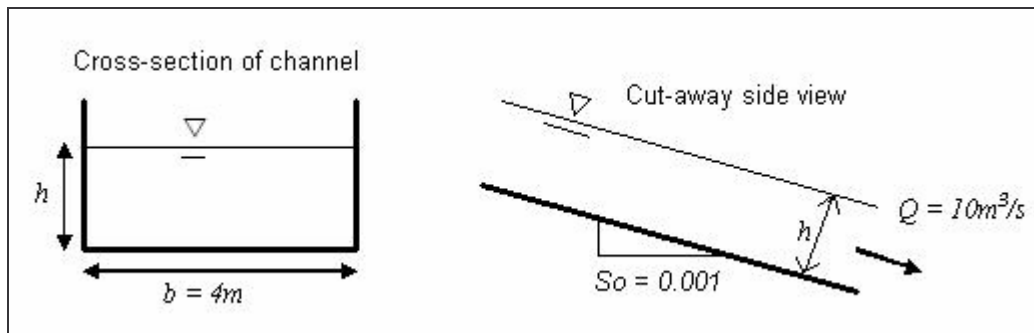

Figure 7: Simulated rectangular channel

The cross-sectional area can be estimated as  $A = b * h = 4 * 1.68 = 6.72\text{ m}^2$  and the velocity can be estimated as  $U = Q/A = 10/6.72 = 1.488\text{ m/s}$ .

The model QUAL2K run for the same input data and by introducing some measurement data for validation concluded to the same results as above (Figure 8).

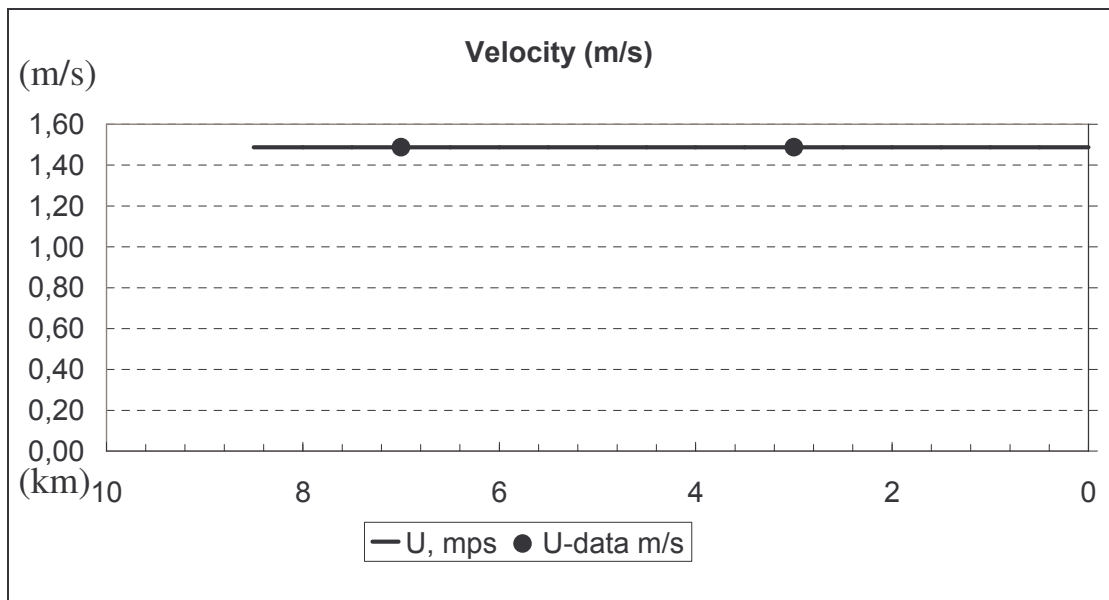
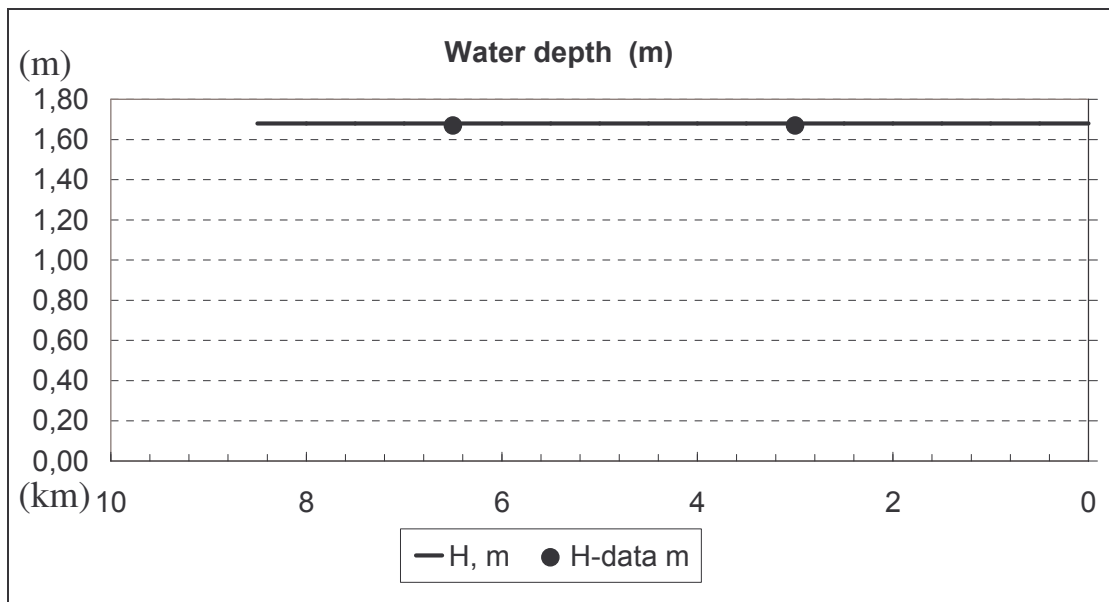

Figure 8: Water depth and velocity simulated by QUAL2K

The model was then applied to the part of the River Neckar from Hofen to Mannheim. The reference year for the first run of the model was 2000. The river was divided into 21 unequally spaced reaches. The downstream end of each reach is controlled by a weir. After introducing the upstream river discharge ( $Q = 2.9 \text{ m}^3/\text{s}$ ), the hourly water temperature and the hourly concentration of the water quality state variables at the river's headwater (Hofen) for 19<sup>th</sup> June 2000, the geometric (Table 4) and meteorological characteristics were prescribed for each of the 21 reaches. There are still missing data from diffuse sources, water extractions and point pollution loads from WWTPs along the river. The loadings from selected Neckar tributaries and those from Moneris areas with an outlet to the River Neckar were considered as point sources (Table 5). Measurement data of river discharge, water temperature and state variables from gauges located at the main stem of the River Neckar were used to validate the model simulations (Table 6).

Table 4: Geometric characteristics of the 21 subdivided reaches of the simulated river

Reach number	Downstream location (km)	Elevation (m)		Bottom Width m	Side Slope	Side Slope	Channel Slope
		Upstream	Downstream				
0	0.000		214.546	45.00	0.60	0.62	0.0007
1	5.82	214.546	210.508	47.00	0.63	0.65	0.000739
2	10.08	210.508	202.664	43.33	0.41	0.26	0.001018
3	17.06	202.664	199.085	46.00	0.35	0.16	0.000476
4	24.37	199.085	193.243	49.00	0.31	0.10	0.000764
5	31.89	193.243	187.304	40.70	0.30	0.24	0.000673
6	39.05	187.304	178.538	47.00	0.23	0.29	0.000844
7	45.74	178.538	173.105	65.16	0.40	0.41	0.000745
8	56.83	173.105	163.461	65.00	0.36	0.40	0.000517
9	64.47	163.461	159.004	52.86	0.21	0.34	0.000832
10	68.472	159.004	150.340	71.00	0.39	0.46	0.001073
11	78.112	150.340	147.531	62.40	0.40	0.45	0.000319
12	88.215	147.531	138.155	53.67	0.10	0.47	0.000672
13	96.123	138.155	132.692	70.80	0.30	0.34	0.000488
14	109.855	132.692	127.025	57.50	0.28	0.41	0.000387
15	120.649	127.025	121.188	66.30	0.14	0.24	0.000456
16	134.352	121.188	116.094	57.00	0.18	0.23	0.000412
17	142.779	116.094	112.129	77.64	0.16	0.20	0.000561
18	151.213	112.129	107.197	68.84	0.54	0.49	0.000507
19	155.943	107.197	104.123	106.69	0.16	0.40	0.000688
20	164.304	104.123	103.342	126.00	0.10	0.17	0.000303
21	175.788	103.342	93.627	55.53	0.29	0.52	0.000649

Table 5: Neckar tributaries and Moneris areas with outlet to the River Neckar considered as point sources in the model

Point source station	Location (km)	Main tributary	Moneris areas with outlet to Neckar
Neustadt	5	Rems	238350→238360→Neckar
Poppenweiler	9	Zipfelbach	none
Murr	20	Murr+Bottwar	none
Besigheim	41	Enz	238410→238441→238445 →238448→238450→238490 →Neckar
Stein	77	Kocher	238610→238640→238650 →238670→238690→Neckar
Jagstfeld	79	Jagst	238810→238820→238830 →238890→Neckar
Mosbach	99	Elz	none
Meckesheim	145	Elsez	238970→238980→Neckar

Table 6: Stations of measurement data for model validation

Station	Loc. (km)	Measurement data
Hofen	0	Mean, maximum and minimum values of Temperature, Dissolved Oxygen, Conductivity and pH
Aldingen	4	
Poppenweiler	11	
Pleidelsheim	27	
Besigheim	41	
Kochendorm FM	76	
Gundelsheim	86	
Rockenau	118	
Neckagemond	149	
Mannheim	179	

Some of the model outputs against distance (km) and comparison with available data are plotted in the graphs below (Figure 9).

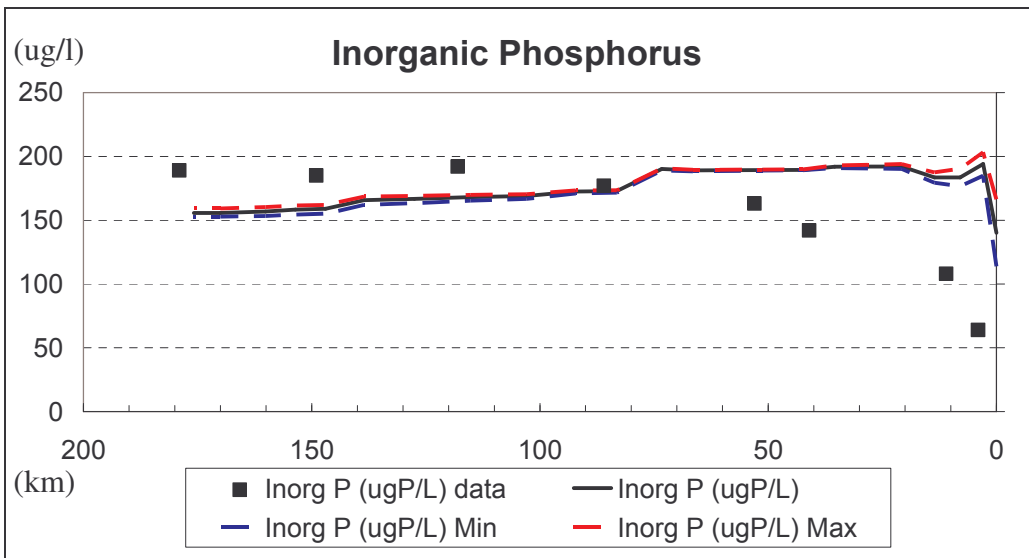
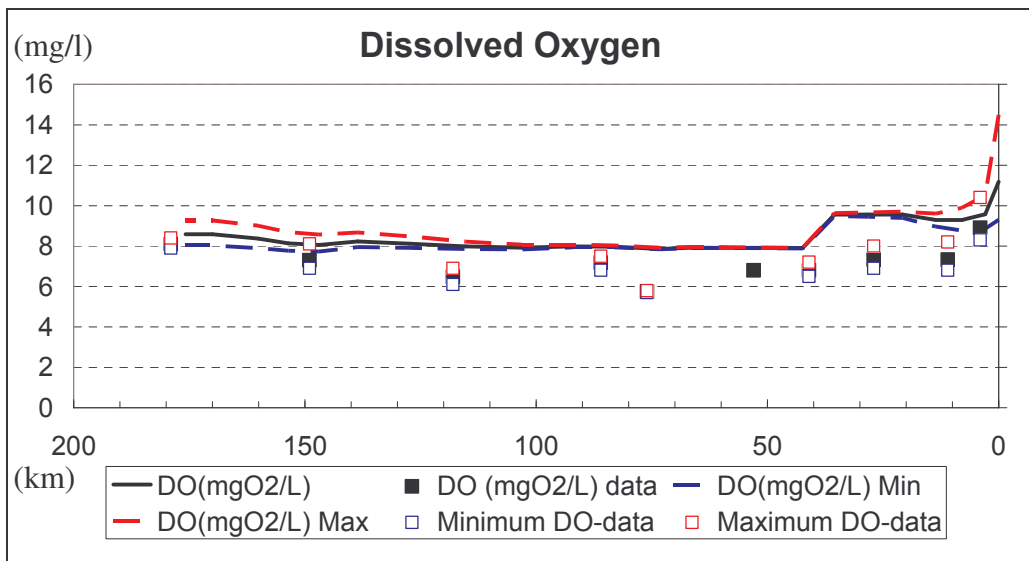
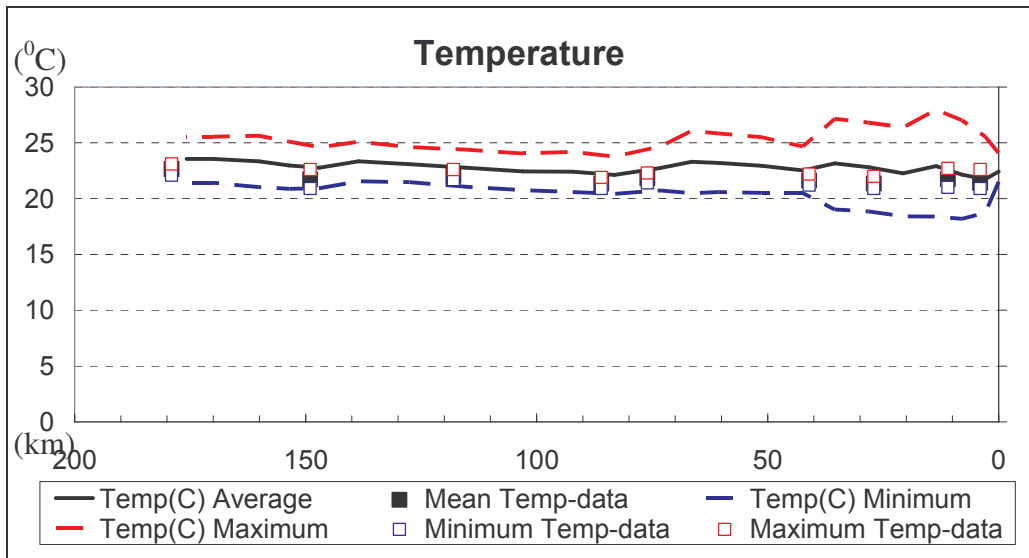

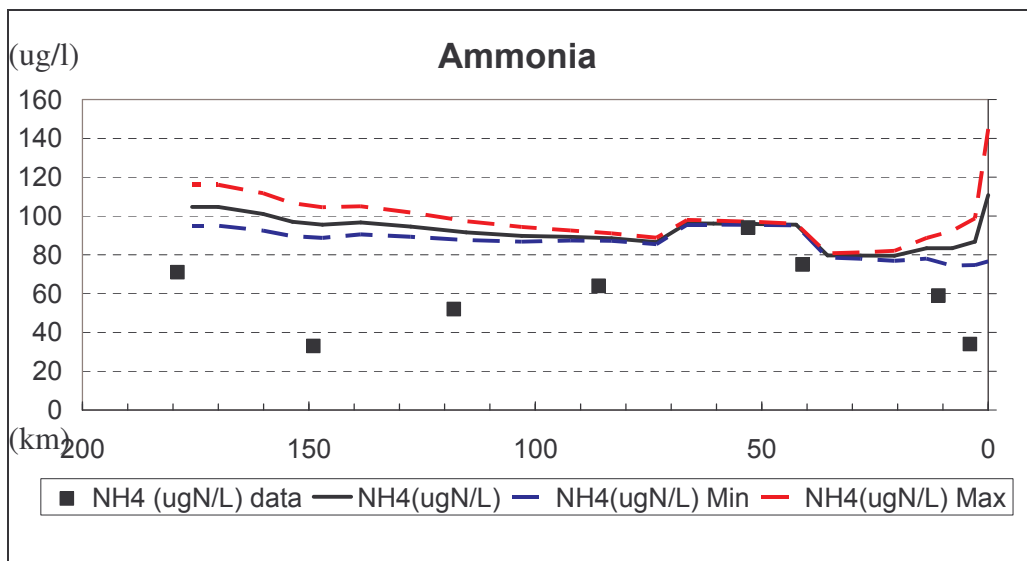
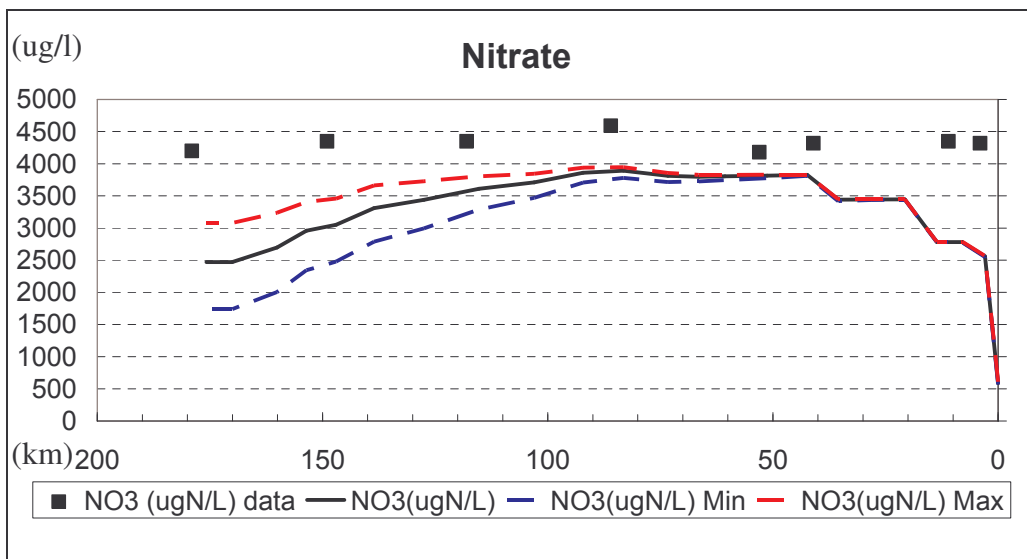
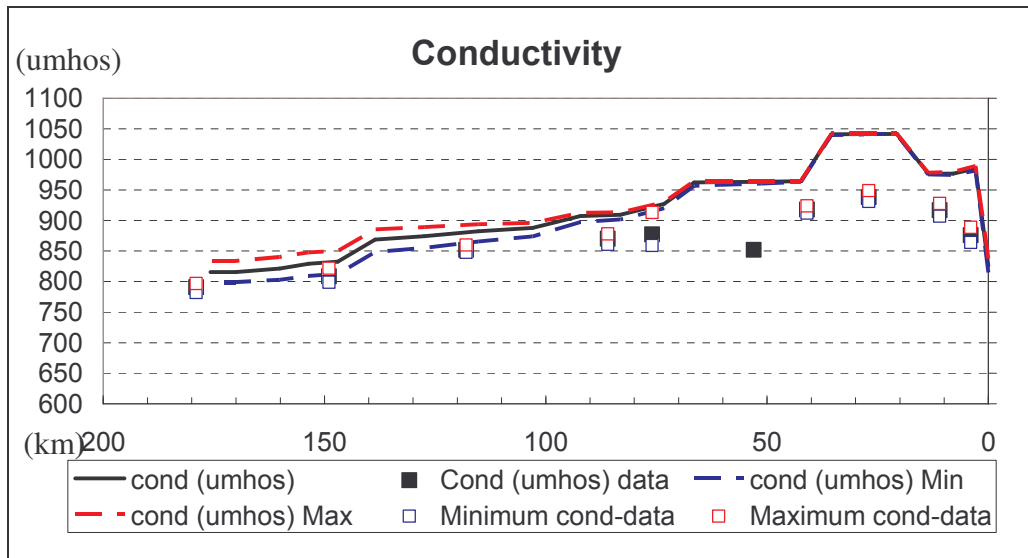

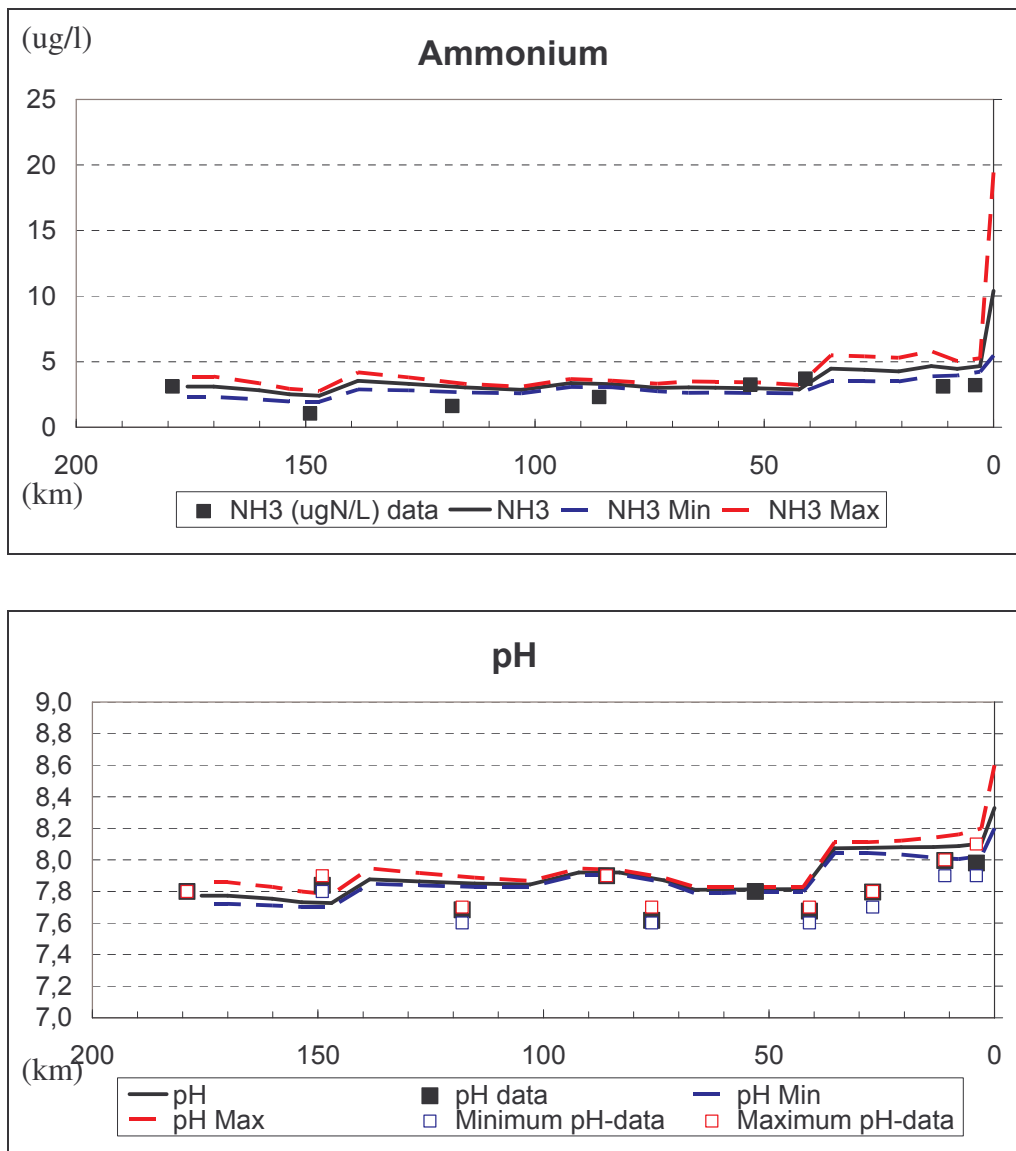
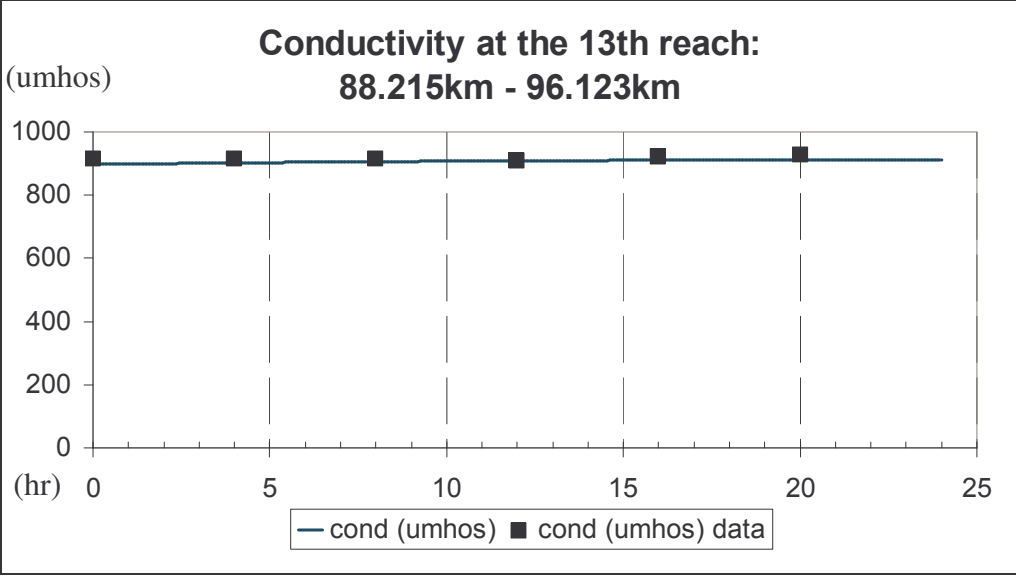
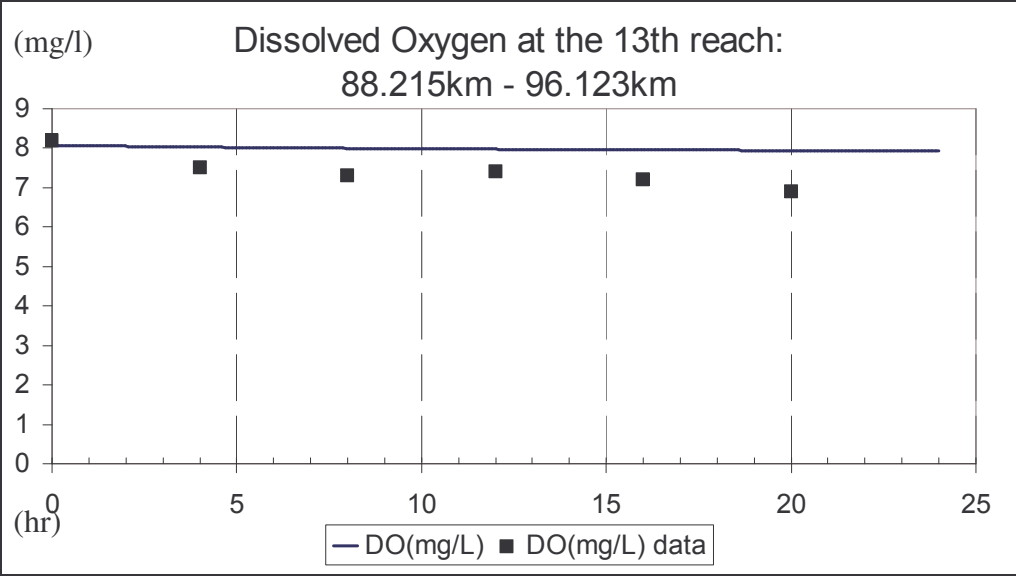
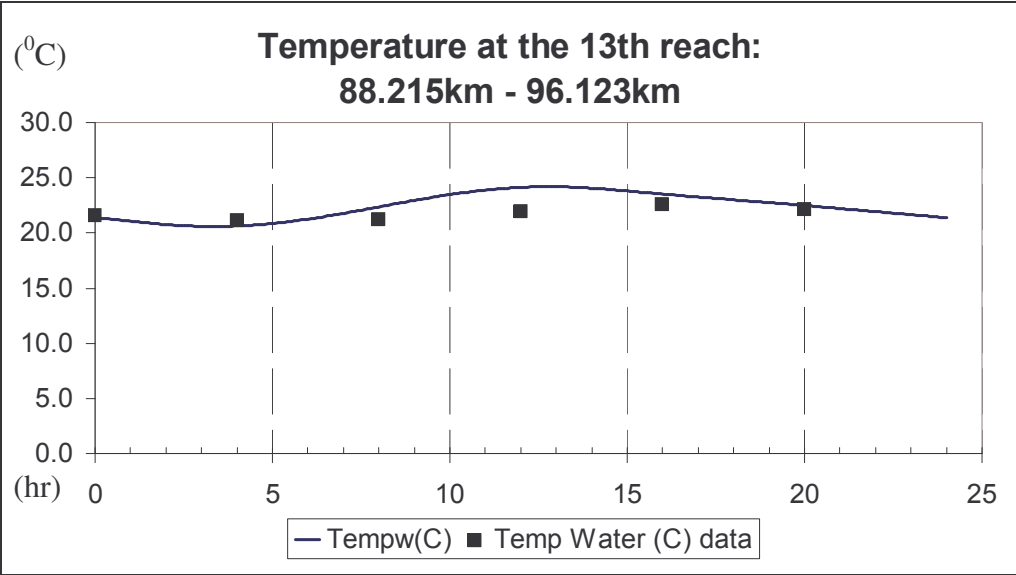

Figure 9: Comparison between model simulation and available data against distance (km)

Some of the model outputs at the 13<sup>th</sup> reach against time (hour) and comparison with available data are plotted in the graphs below (Figure 10).



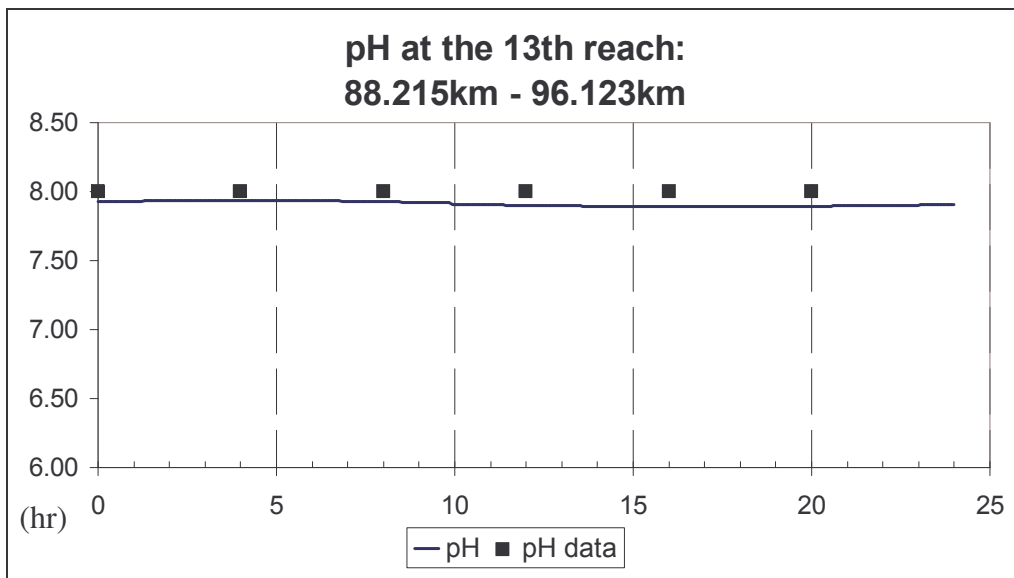

Figure 10: Comparison between model simulation and available data against time (hr)

### Model Uncertainty Analysis

Confidence in the model results may be compromised because QUAL2K uses over a hundred parameters, the values of which are not precisely known. In addition uncertainties are due to incomplete knowledge about the magnitude of various inputs and abstractions as well as about their precise location along the river. All these uncertainties may influence up to 15 state variables used in the model.

Further developments will focus on the most important input variables to be modified and on locations along the river where uncertainty analysis could be applied. Uncertainty analysis techniques that can be employed are: sensitivity analysis, first order error analysis, Monte Carlo and fuzzy logic-based simulation. For the Neckar Basin a balance between existing data and local expertise will be used in order to minimize complexity for model uncertainty analysis.

## BRIEF DESCRIPTION OF THE USER INTERFACE OF QUAL2K

The computer code used to implement the calculations for QUAL2K (Q2K) is written in Visual Basic for Applications (VBA). Excel serves as the user interface. Colour is used to signify whether information is to be input by the user or output by the program:

**Pale Blue** designates variable and parameter values that are to be entered by the user.

**Pale Yellow** designates data that the user enters. This data are then displayed on graphs generated by Q2K and used for the validation of the model simulation.

**Pale Green** designates output values generated by Q2K.

**Dark solid colours** are used for labels and should not be changed.

All worksheets include two buttons:

**Open Old Files.** When this button is clicked, the file browser will automatically open to allow you to access a data file. All QUAL2K data files have the extension, \*.q2k.

**Run.** This button causes Q2K to execute and to create a data file that holds the input values. The data file can then be accessed later using the **Open Old File** button.

### Input data Worksheets

#### 1. QUAL2K Worksheet

The QUAL2K Worksheet is used to enter general information regarding a particular model application.

1	<b>QUAL2K</b>		
2	<b>Stream Water Quality Model</b>		
3	<b>Steve Chapra and Greg Pelletier</b>		
4			
5			
6			
7	<b>System ID:</b>		
8	<b>River name</b>	neckar3	Open Old File
9	<b>Saved file name</b>	neckar3	
10	<b>Directory where file saved</b>	C:\RIVERTWIN\QUAL2K_work	Run
11	<b>Month</b>	6	
12	<b>Day</b>	19	
13	<b>Year</b>	2000	
14	<b>Time zone</b>	Central	
15	<b>Daylight savings time</b>	Yes	
16	<b>Calculation:</b>		
17	<b>Calculation step</b>	0,25 hours	
18	<b>Final time</b>	3 day	
19	<b>Program determined calc step</b>	hours	
20	<b>Time of last calculation</b>	minutes	
21	<b>Time of sunrise</b>		
22	<b>Time of solar noon</b>		
23	<b>Time of sunset</b>		
24	<b>Photoperiod</b>	hours	
25			
26			
27			
28			
29			
30			
31			
32			
33			

QUAL2K / Headwater / Reach / Air Temperature / Dew Point Temperature / Wind Speed / Cloud Cover / Shade





### 5. Rate parameters Worksheet

Recommended values for these parameters are given in the model's manual documentation.

Parameter	Value	Units	Symbol
<b>Stoichiometry:</b>			
Carbon	40	mgC	$\mu C$
Nitrogen	7,2	mgN	$\mu N$
Phosphorus	1	mgP	$\mu P$
Dry weight	100	mgD	$\mu D$
Chlorophyll	1	mgA	$\mu A$
<b>Inorganic suspended solids:</b>			
Settling velocity	1	m/d	$v_s$
<b>Oxygen:</b>			
Reaeration model	Internal		
Temp correction	1,024		$\theta_o$
O2 for carbon oxidation	2,69	gO2/gC	$\gamma_{CO2}$
O2 for NH4 nitrification	4,57	gO2/gN	$\gamma_{NO3}$
Oxygen inhib CBOD oxidation model	Exponential		
Oxygen inhib CBOD oxidation parameter	0,60	L/mgO2	$K_{O2CBOD}$
Oxygen inhib nitrification model	Exponential		
Oxygen inhib nitrification parameter	0,60	L/mgO2	$K_{O2NO3}$
Oxygen enhance denitrification model	Exponential		
Oxygen enhance denitrification parameter	0,60	L/mgO2	$K_{O2NO2}$
<b>Slow CBOD:</b>			
Hydrolysis rate	2	/d	$k_{hyd}$
Temp correction	1,047		$\theta_{hyd}$
<b>Fast CBOD:</b>			
Oxidation rate	4	/d	$k_{fcb}$
Temp correction	1,047		$\theta_{fcb}$
<b>Organic N:</b>			
Hydrolysis	0,05	/d	$k_{hyd}$
Temp correction	1,07		$\theta_{hyd}$
<b>Ammonium:</b>			
Nitrification	4	/d	$k_{nit}$
Temp correction	1,07		$\theta_{nit}$
<b>Nitrate:</b>			
Denitrification	1	/d	$k_{den}$
Temp correction	1,07		$\theta_{den}$
Sed denitrification transfer coeff	0	m/d	$\nu_{den}$
Temp correction	1,07		$\theta_{den}$
<b>Organic P:</b>			
Hydrolysis	2	/d	$k_{hyd}$
Temp correction	1,07		$\theta_{hyd}$

<b>Phytoplankton:</b>			
Max Growth	2,5	/d	$k_{gr}$
Temp correction	1,07		$\theta_{gr}$
Respiration	0,1	/d	$k_{res}$
Temp correction	1,07		$\theta_{res}$
Death	0	/d	$k_{de}$
Temp correction	1		$\theta_{de}$
Nitrogen half sat constant	15	ugN/L	$K_{N0.5}$
Phosphorus half sat constant	2	ugP/L	$K_{P0.5}$
Light model	Half saturation		
Light constant	57,6	langleys/d	$K_{L0.5}$
Ammonia preference	25	ugN/L	$K_{NH4}$
Settling velocity	0,15	m/d	$v_s$
<b>Bottom Algae:</b>			
Max Growth	60	gD/m <sup>2</sup> /d	$C_{grb}$
Temp correction	1,07		$\theta_{grb}$
Respiration	1	/d	$k_{resb}$
Temp correction	1,07		$\theta_{resb}$
Death	0,25	/d	$k_{deb}$
Temp correction	1,07		$\theta_{deb}$
Nitrogen half sat constant	300	ugN/L	$K_{N0.5b}$
Phosphorus half sat constant	100	ugP/L	$K_{P0.5b}$
Light model	Half saturation		
Light constant	60	langleys/d	$K_{L0.5b}$
Ammonia preference	25	ugN/L	$K_{NH4b}$
<b>Detritus (POM):</b>			
Dissolution	5	/d	$k_{dep}$
Temp correction	1,07		$\theta_{dep}$
Settling velocity	1	m/d	$v_{sp}$
<b>Pathogens:</b>			
Decay	0,8	/d	$k_{pa}$
Temp correction	1,07		$\theta_{pa}$
Settling velocity	1	m/d	$v_s$
<b>pH:</b>			
Partial pressure of carbon dioxide	347	ppm	$p_{CO2}$

### 6. Light and Heat Worksheet

This worksheet is used to enter information related the system's light and heat parameters. Recommended values for these parameters are given in the model's manual documentation.

2	<b>Stream Water Quality Model</b>		
3	<b>Neckar (1916/2000)</b>		
4	<b>Light Parameters and Surface Heat Transfer Models:</b>		
5			
6			
7	Parameter	Value	Unit
8	Photosynthetically Available Radiation	0,47	
9	Background light extinction	0,2	/m
10	Linear chlorophyll light extinction	0,0088	1/m-(ugA/L)
11	Nonlinear chlorophyll light extinction	0,054	1/m-(ugA/L) <sup>2</sup> /3
12	ISS light extinction	0,052	1/m-(mgD/L)
13	Detritus light extinction	0,174	1/m-(mgD/L)
14	<b>Solar shortwave radiation model</b>		
15	Atmospheric attenuation model for solar	Bras	
16	Bras solar parameter (used if Bras solar model is selected)		
17	atmospheric turbidity coefficient (2=clear, 5=smoggy, default=2)	2	
18	Ryan-Stolzenbach solar parameter (used if Ryan-Stolzenbach solar model is selected)		
19	atmospheric transmission coefficient (0.70-0.91, default 0.8)	0,8	
20	<b>Downwelling atmospheric longwave IR radiation</b>		
21	atmospheric longwave emissivity model	Brunt	
22	Evaporation and air convection/conduction		
23	wind speed function for evaporation and air convection/conduction	Brady-Graves-Geyer	

### 7. Point Sources Worksheet



**Control data Worksheets**

Available measurement data of hydraulic characteristics, temperature and water quality constituents at specific locations along the river are entered in five worksheets.

1	<b>QUAL2K</b>				
2	<b>Stream Water Quality Model</b>				
3	<b>Neckar(1916 2000)</b>				
4	<b>Hydraulics Data:</b>				
5					
6					
7	<b>Distance</b>	<b>Q-data</b>	<b>H-data</b>	<b>U-data</b>	<b>Travel time</b>
8	<b>x(km)</b>	<b>m<sup>3</sup>/s</b>	<b>m</b>	<b>m/s</b>	<b>data (d)</b>
9					
10					

1	<b>QUAL2K</b>			
2	<b>Stream Water Quality Model</b>			
3	<b>Neckar(1916 2000)</b>			
4	<b>Temperature Data:</b>			
5				
6				
7	<b>Distance</b>	<b>Mean</b>	<b>Minimum</b>	<b>Maximum</b>
8	<b>x(km)</b>	<b>Temp-data</b>	<b>Temp-data</b>	<b>Temp-data</b>
9				
10				

1	<b>QUAL2K</b>					
2	<b>Stream Water Quality Model</b>					
3	<b>Neckar(1916 2000)</b>					
4	<b>Water Quality Data (min &amp; max):</b>					
5						
6						
7	<b>Distance</b>	<b>Cond (umhos)</b>	<b>ISS (mgD/L)</b>	<b>DO (mgO<sub>2</sub>/L)</b>	<b>CBOD (mgO<sub>2</sub>/L)</b>	<b>...</b>
8	<b>km</b>	<b>data</b>	<b>data</b>	<b>data</b>	<b>data</b>	<b>data</b>
9						
10						

Minimum and maximum measurement data for water quality data at specific distance are entered in 2 different worksheets

The worksheet below is used to enter known mean daily values for water quality data and other concentrations and fluxes at specific distance.

1	<b>QUAL2K</b>								
2	<b>Stream Water Quality Model</b>								
3	<b>Neckar(1916 2000)</b>								
4	<b>Water Quality Data:</b>								
5									
6									
7	<b>Distance</b>	<b>Cond (umhos)</b>	<b>ISS (mgD/L)</b>	<b>DO (mgO<sub>2</sub>/L)</b>	<b>CBOD (mgO<sub>2</sub>/L)</b>	<b>...</b>	<b>Bot Alg (mgA/m<sup>3</sup>)</b>	<b>TN (ugN/L)</b>	<b>TP (ugP/L)</b>
8	<b>km</b>	<b>data</b>	<b>data</b>	<b>data</b>	<b>data</b>	<b>data</b>	<b>data</b>	<b>data</b>	<b>data</b>
9									
10									

Other Concentrations and Fluxes (if known) that entered are:  
 Bottom Algae, Total nitrogen-data, Total phosphorus-data, Total suspended solids-data, NH<sub>3</sub> (unionized ammonia)-data, % saturation-data, SOD-data, Sediment ammonium flux, Sediment methane flux, Sediment inorganic phosphorus flux, Ultimate carbonaceous BOD, Total Organic Carbon.



### 3. Temperature Output

This worksheet summarizes the temperature output for each model reach.

1	<b>QUAL2K</b>								
2	<b>Stream Water Quality Model</b>								
3	<b>neckar (6/19/2000)</b>						Run	Open Old File	
4	<b>Temperature Output</b>								
5									
6									
7	<b>Reach</b>	<b>Distance</b>	<b>Temp(C)</b>	<b>Temp(C)</b>	<b>Temp(C)</b>				
8	<b>Label</b>	<b>x(km)</b>	<b>Average</b>	<b>Minimum</b>	<b>Maximum</b>				
9									
10									
11									

### 4. WQ Output

This worksheet summarizes the mean concentration output for each model reach.

<b>QUAL2K</b>									
<b>Stream Water Quality Model</b>									
<b>neckar (6/19/2000)</b>					Run	Open Old File			
<b>Constituent Summary</b>									
<b>Reach Label</b>	<b>x(km)</b>	<b>cond (umhos)</b>	<b>ISS (mgD/L)</b>	<b>DO(mgO2/L)</b>	<b>CBOD (mgO2/L)</b>	<b>No(ugN/L)</b>	<b>NH4(ugN/L)</b>	<b>...</b>	<b>NH3</b>

Two similar worksheets summarize the minimum and maximum concentration output for each model reach.

### 5. Sediment Fluxes Worksheet

This worksheet summarizes the fluxes of oxygen and nutrients between the water and the underlying sediment compartment for each model reach.

<b>QUAL2K</b>							
<b>Stream Water Quality Model</b>							
<b>neckar (6/19/2000)</b>					Run	Open Old File	
<b>Sediment Flux Summary</b>							
<b>Reach</b>	<b>Distance</b>	<b>SOD</b>	<b>Sed Flux CH4</b>	<b>Sed Flux NH4</b>	<b>Sed Flux Inorg P</b>	<b>Sed Flux NO3</b>	
<b>Label</b>	<b>x(km)</b>	<b>gO2/m^2/d</b>	<b>gO2/m^2/d</b>	<b>mgN/m^2/d</b>	<b>mgP/m^2/d</b>	<b>mgN/m^2/d</b>	

6. Diel Output Worksheet.

This worksheet displays diel output for temperature and water quality state variable data. Along with the water temperature, the temperature of the surface sediments is also displayed. In addition, the diel variation in total suspended solids, total phosphorus, total nitrogen, and oxygen saturation are also displayed.

A	B	C	D	E	F	G	H	I	J	K
nekar (6/19/2000)										
Reach	13					Run	Open Old File			
<i>t (hr)</i>	<i>Tempw(C)</i>	<i>Temps(C)</i>	<i>cond (umhos)</i>	<i>ISS (mg/L)</i>	<i>DO(mg/L)</i>	<i>CBOD (mgO2/L)</i>	<i>No(ugN/L)</i>	<i>NH4(ugN/L)</i>	...	<i>NH3 (ugN/L)</i>

**Spatial Charts**

QUAL2K displays a series of charts that plot the model output and data versus distance (km) along the river.

An example of the plot for dissolved oxygen is shown below. The black line is the simulated mean DO (as displayed on the WQ Worksheet), whereas the dashed blue line is the minimum (WQ Min Worksheet) and the dashed red line is the maximum (WQ Max Worksheet) values, respectively. The black squares are the measured mean data points that were entered on the WQ Data Worksheet. The blue squares are the minimum (WQ Min Worksheet) and the red squares are the maximum (WQ Max Worksheet) data points, respectively.

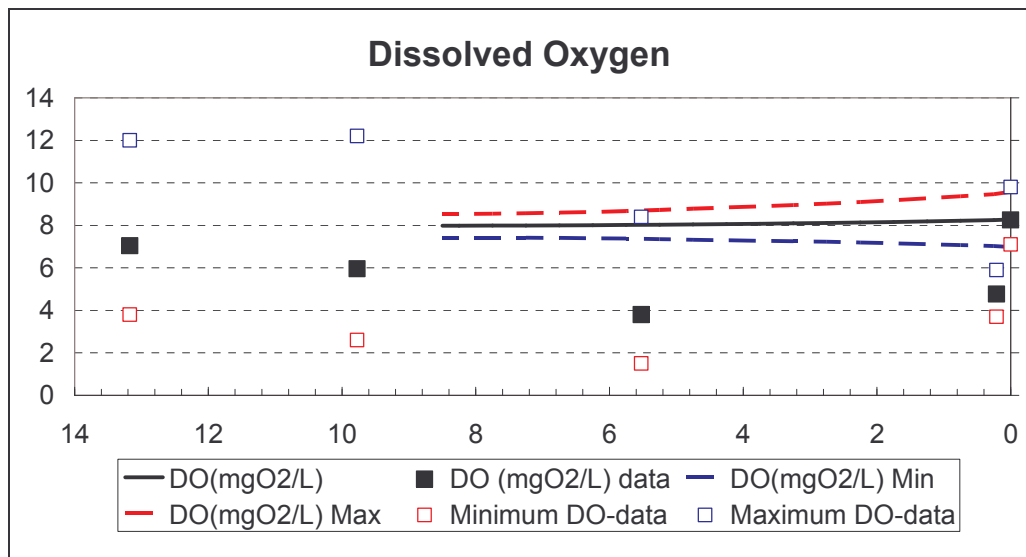

The following series of variables are plotted versus distance (km) along the river:

<u>Hydraulics Plots</u>	<u>Temperature and state-variable plots</u>	<u>Additional State-variable plots</u>
<ul style="list-style-type: none"> <li>• Travel Time</li> <li>• Flow</li> <li>• Velocity</li> <li>• Depth</li> <li>• Reaeration</li> </ul>	<ul style="list-style-type: none"> <li>• Temperature</li> <li>• Conductivity</li> <li>• ISS (Inorganic suspended solids)</li> <li>• Dissolved oxygen</li> <li>• Detritus</li> <li>• Slow CBOD</li> <li>• Fast CBOD</li> <li>• Dissolved organic nitrogen</li> <li>• NH<sub>4</sub> (Ammonia nitrogen)</li> <li>• NO<sub>3</sub> (Nitrate nitrogen)</li> <li>• Dissolved organic phosphorus</li> <li>• Inorganic phosphorus</li> <li>• Phytoplankton</li> <li>• Bottom algae in units of gD/m<sup>2</sup></li> <li>• Pathogen</li> <li>• Alkalinity</li> <li>• pH</li> </ul>	<ul style="list-style-type: none"> <li>• Bottom algae in units of mgA/m<sup>2</sup></li> <li>• CBODu</li> <li>• NH<sub>3</sub></li> <li>• TN and TP</li> <li>• TSS</li> </ul>
		<u>Sediment-water plots</u>
		<ul style="list-style-type: none"> <li>• SOD</li> <li>• CH<sub>4</sub> Sed Flux</li> <li>• NH<sub>4</sub> Sed Flux</li> <li>• Inorg P Sed Flux</li> </ul>

## Diel Charts

QUAL2K displays a series of charts that plot the model output and data versus time of day (in hours) for temperature and the model state variables. The figure below shows an example of the diel plot for pH. The red line is the simulated pH (as displayed on the Diel Worksheet). The black squares are the measured data points that were entered on the Diel Data Worksheet.

